



Description & Features:

- Highly accurate reading of low pressures
- Brass wetted parts
- Adjustable red set pointer
- Built in over pressure protection
- Restricted orifice
- ASME B40.100 compliant
- CRN registered
- 5 year warranty

Applications:

- Suitable for measuring low pressure gas media
- Used to measure natural gas pressure as well as air flow indication and leak detection
- Low pressure pumps, air compressors, air filters, gas burners, ovens, regulators and respirators

Specifications

Dial	4" (100mm), white aluminum dial with black, blue and red markings
Case	Steel, painted black
Lens	Polycarbonate with adjustable red set pointer
Ring	Steel
Socket	Brass
Connection	1/4" NPTM gauge with 3/4" NPTF x M8x0.8 chrome plated test block
Diaphragm Element	Phosphor bronze
Movement	Brass
Pointer	Aluminum, anodized black
Welding	Solder/brazed
Working Pressure	60% of full scale value (fluctuating) 75% of full scale value (static)
Overload Protection	2X full scale value
Ambient/Process Temperature	-40°F to 150°F (-40°C to 65°C)
Accuracy	±1% Grade 1A
Enclosure Rating	IP52
Warning	 WARNING: This product can expose you to chemicals including lead, which is known to the State of California to cause cancer and birth defects or other reproductive harm. For more information go to www.P65Warnings.ca.gov .

Order Codes (products in bold are normally in stock)

Pressure Range	Code
0/6 psi/Hg	PGTK314CM.
0/15 psi/Hg	PGTK315CM.

Gauge

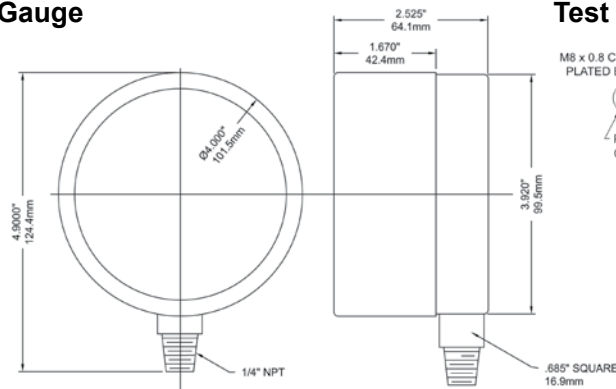

Test Block

