



**SCV VALVE**  
Innovative Valve Solutions®



[281] 482-4728 • [www.scvvalve.com](http://www.scvvalve.com)



## 1-Piece Flanged Floating Ball Valves - B16.34 - Reduced Port

## 2-Piece Flanged Floating Ball Valves - B16.34 - Full Port

Class: 150 - 1500  
Sizes: 1/2" - 12"

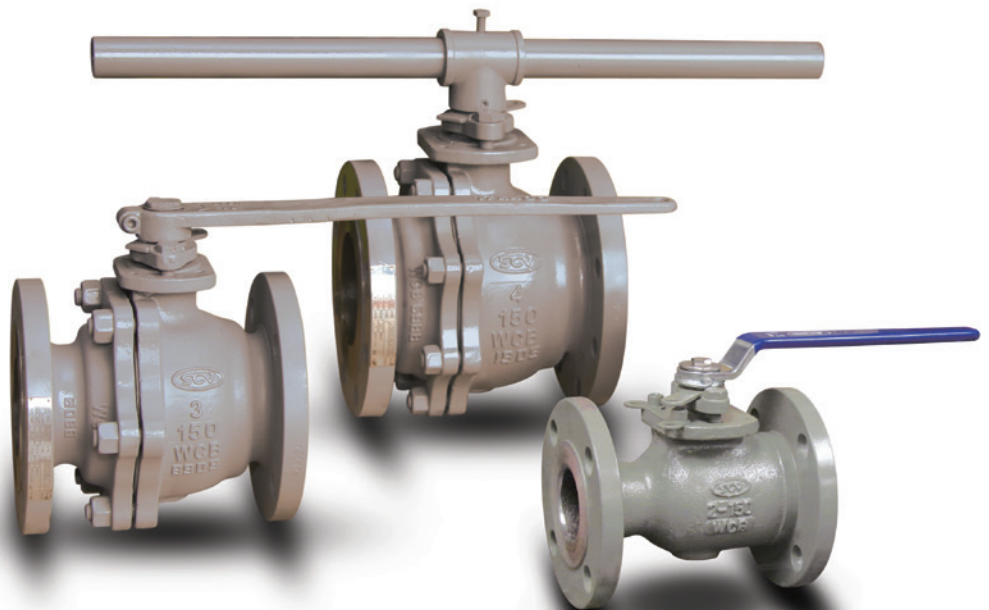



**SCV VALVE**



**SCV VALVE** manufactures some of the most dependable cast steel Floating Ball Valves in the industry. Our products are manufactured and tested in accordance with respective API, ASME, and ANSI standards. The SCV design offers many features and options beneficial for oil, gas, and liquid applications making it one of the most preferred ball valves on the market.

**Innovative Valve Solutions.®**

## 1-Piece Flanged Floating Ball Valves - Reduced Port - B16.34

- Basic Design: ANSI/ASME B16.34, conforms to API 6D
- Face-to-Face Dimension: ANSI/ASME B16.10
- Flange End Dimension: ANSI/ASME B16.5
- Inspection & Testing: API 598
- Fire Safe Design: API 607/BS 6755

## 2-Piece Flanged Floating Ball Valves - Full & Reduced Por - B16.34

- Basic Design: ANSI/ASME B16.34, conforms to API 6D
- Face-to-Face Dimension: ANSI/ASME B16.10
- Flange End Dimension: ANSI/ASME B16.5
- Inspection & Testing: API 598
- Fire Safe Design: API 607/BS 6755

**Note:** Not recommended for throttling applications.

**Note:** SCV reserves the right to change any technical design and dimensional data without prior notice. Please contact SCV to confirm all Dimensions and Data offered in this catalog.





# Table of Contents

	Page
Table of Contents.....	1
Complete Product Line.....	2
Certifications.....	3
· American Petroleum Institute (API)	
· ISO 9001:2008	
· Canadian Registration Numbers	
· CE PED	
Figure Number Chart .....	4 & 5
Technical Data for Optional Seal & Seat Selections .....	6
SCV Valve Soft Good Chemical Compatibility.....	7
Seal & Seat Pressure Temperature Chart .....	7
Valve ID Tag & Valve Markings Identification.....	8
<b>1-PIECE FULL PORT FLANGED FLOATING BALLS - REDUCED PORT .....</b>	<b>9</b>
Expanded View .....	10
Bill of Materials & Features.....	11
150 Class Reduced Port.....	12
300 Class Reduced Port .....	13
<b>2-PIECE FULL PORT FLANGED FLOATING BALLS - FULL PORT .....</b>	<b>14</b>
Expanded View .....	15
Bill of Materials & Features.....	16
150 Class Full Port.....	17
300 Class Full Port.....	18
600 Class Full Port.....	19
1500 Class Full Port .....	20
Cv Values, Operating Torques.....	21
Pressure Temperature Ratings .....	22,23,24
Flange Dimensions.....	25 & 26
Terms and Conditions.....	27

# Complete Product Line

## THRU CONDUIT GATES - SLAB & EXPANDING

**Design: API 6D**

Sizes: 2" - 42"  
Class: 150 - 1500

Standard stock.

**Design: API 6A**

Sizes: 9", 11" & 13-5/8"  
Pressure: 2000, 3000, 5000

Limited inventory availability.  
All sizes and pressure classes made to order.

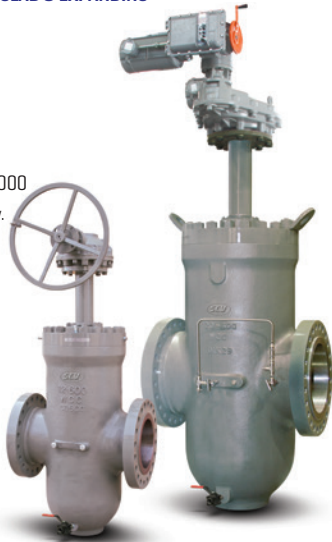

## PISTON CHECKS

**Design: API 6D**

Sizes: 2" - 24"  
Class: 150 - 2500

Standard stock.



## GLOBES

**Design: API 623**

Sizes: 2" - 24"  
Class: 150 - 2500

Limited inventory availability.  
All sizes and pressure classes made to order.



## 3-PIECE TRUNNION BALLS

**Design: API 6D**

Sizes: 2" - 42"  
Class: 150 - 2500

Standard stock.

**Design: API 6A**

Sizes: 2-1/16" - 7-1/6"  
Pressure: 2000, 3000, 5000

Limited inventory availability.  
All sizes and pressure classes made to order.

Bore Coating: Scotchkote™ 134



## FULL PORT SWING CHECKS

**Design: API 6D**

Sizes: 2" - 36"  
Class: 150 - 2500

Standard stock.



Exterior Coating: Epoxy

## WEDGE GATES

**Design: API 600**

Sizes: 2" - 48"  
Class: 150 - 2500

Limited inventory availability. All sizes and pressure classes made to order.



## FLOATING BALL VALVES

**Design: B16.34**

Sizes: 1/2" - 12"  
Class: 150 - 1500

Standard stock.



## PRESSURE BALANCED LUBRICATED PLUGS

**Design: API 6D**

Sizes: 2" - 36"  
Class: 150 - 2500

Standard stock.

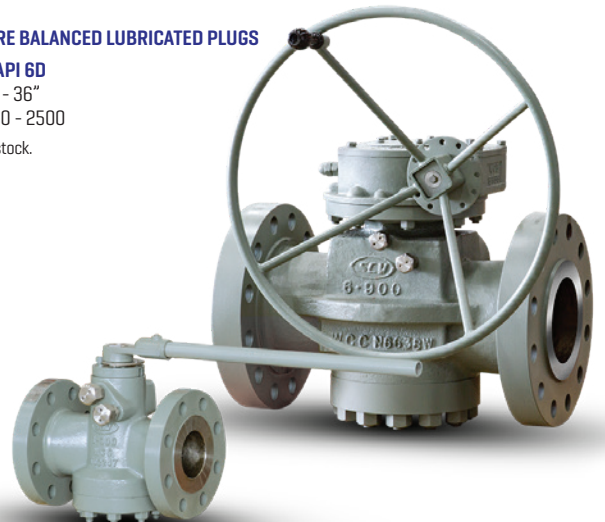

# Certifications & Registrations

## American Petroleum Institute (API)

### API 6A Certification



Note: Extension letter available on our website.

### API 6D Certification



Note: Extension letter available on our website.

### ISO 9001:2015 Certificate



### CE PED Certificate



### Canadian Registration Number

- Alberta  
- OC07063.2
- New Brunswick  
- OC07063.27
- Northwest Territory  
- OC07063.25
- Nunavut  
- OC07063.2N
- Ontario  
- OC07063.25
- Yukon  
- OC07063.2
- British Columbia  
- OC07063.21
- New Foundland & Labrador  
- OC07063.20
- Novascotia  
- OC07063.27
- Manitoba  
- OC07063.24
- Prince Edward Island  
- OC07063.29

# SCV Figure Number Chart

Note: SCV Figure Chart is subject to change without notice.

1

2

3

4

5

6

7

8

Valve Type	Bore Size	Class	Body/Bonnet Conf.	Body Material	Obturator Material	Ends	Operator
BAL = Trunnion Ball Valve	50 = 1/2"	01 = 150	B = Bolted	02 = A352 LCC	01 = A352 LLC + 410	A = RF x WE	/ = N/A
CEG = Compact Expanding Gate Valve	75 = 3/4"	03 = 300	L = Lug Style	06 = A351 CF8M	02 = A352 LCC + ENP	B = RTJ x WE	B = Bare Stem
DCK = Dual Plate Check Valve	01 = 1"	04 = 400	P = Pressure Seal	08 = A216 WCC	06 = A216 WCC + ENP	D = RF x RTJ	D = Dual Acting Actuator
EPG = Expanding Gate Valve	15 = 1-1/2"	06 = 600	S = Seal Weld	10 = A216 WCB	09 = A351 CF8M	E = RTJ x RF	E = Electric Actuator
FBV = Floating Ball Valve	02 = 2"	09 = 900	T = Top Entry	11 = A352 LCB	10 = A216 + CR13	J = RTJ	G = Gear
FCK = Full Port Swing Check Valve	21 = 2-1/16"	15 = 1500	U = Union	12 = A350 LF2	11 = CR13 HF	K = WE x RF	H = Handwheel
GAT = Wedge Gate Valve	25 = 2-1/2"	20 = 2000		13 = A105	12 = A105 + CR13	L = WE x RTJ	I = Linear Actuator
GLB = Globe Valve	27 = 2-9/16"	25 = 2500		16 = A217 WCG	13 = A105 + ENP	R = RF	L = Lever
PCK = Piston Check Valve	03 = 3"	30 = 3000		30 = A29 4130	14 = A694 Gr. F60 + ENP	W = WE	
PLG = Lubricated Plug Valve	31 = 3-1/8"	50 = 5000		36 = A182 316	15 = A350 LF2 + ENP		
PSG = Parallel Slide Gate Valve	37 = 3-9/16"	10 = 10000		51 = A182 F51 Duplex	16 = A216 WCC + 316		
RSB = Rising Stem Ball Valve	04 = 4"			55 = A182 F55 Duplex	17 = 17-4 PH		
SCK = Conv. Port Swing Check Valve	41 = 4-1/16"			60 = A216 WCC + Inconel 625	20 = A216 WCB + Ni65		
TCG = Slab Gate Valve	05 = 5"			87 = A487 4C	23 = A182 316L + Stellite 21		
	51 = 5-1/8"			88 = A890-4A	34 = A182 304		
	06 = 6"				35 = A182 316 HF		
	71 = 7-1/16"				36 = A182 316		
	08 = 8"				41 = A182 F6A Class 2		
	09 = 9"				42 = A182 F6A + Nitride		
	10 = 10"				51 = A182 F51 Duplex		
	23 = 10-3/8"				52 = A351 CF8M + Stellite 6		
	11 = 11"				54 = A182 F51 Duplex + CoCr-A		
	12 = 12"				59 = A352 LCC + Stellite 6		
	19 = 12-3/8"				60 = A105 + HF		
	13 = 13-5/8"				61 = A105 + Nitride + Stellite 6		
	14 = 14"				62 = A105 + Inconel 625		
	16 = 16"				69 = A350 LF2 + Tungsten Carbide		
	17 = 16-3/4"				73 = A182 410 + Tungsten Carbide		
	18 = 18"				81 = A350 LF2 + Nitride + HF		
	20 = 20"				85 = A743 CA15 + Nitride		
	22 = 22"				88 = A890-4A		
	24 = 24"				96 = A216 WCB + CR13		
	26 = 26"						
	28 = 28"						
	30 = 30"						
	32 = 32"						
	34 = 34"						
	36 = 36"						
	38 = 38"						
	40 = 40"						
	42 = 42"						
	48 = 48"						
	52 = 52"						
	56 = 56"						
	60 = 60"						





# Technical Data for Optional Seal & Seat Selections

## Optional Seal Selections

Code	Material	Description
B	BUNA	Also called Buna N or Nitrile, this sealing material is widely used because of its compatibility with most hydraulic fluid media, including petroleum oils, water, water glycol, Di-Ester based fluids, air, and inactive gases. The temperature of this material ranges from -54C to +135C [-65F to +275F].
N	NEOPRENE	This sealing material is excellent for refrigerants, ammonia, and freon. Its temperature range is from -37C to +107C [-35F to +225F].
E	EPDM	Also called Ethylene-Propylene, this sealing material is recommended for low pressure steam, hot water, phosphate ester base fluid, weak alkalines, and acids. This material is not recommended for petroleum service, hydrocarbons, alcohol, and radiation. Its temperature range is -54C to 149C [-65F to +250F].
V	VITON	Also called Fluorocarbon Rubber (FKM), this material is known for being excellent in condition up to +204C [+400F]. Viton offers excellent resistance to aggressive fuels and chemicals.
T	PTFE	Teflon has excellent resistance to a wide range of chemicals. It is excellent at pressures below 1500 PSI. It can withstand temperatures up to +204C [+400F].
R	NBR	NBR is typically resistant to mineral oil-based lubricants and greases, hydraulic fluids, hydrocarbons, and water. NBR is not resistant to polar solvents or chlorinated hydrocarbons. The material's temperature range is from -30C to +100C [-22F to +212F].
H	HNBR	HNBR is simply hydrogenated NBR. It is typically resistant to mineral oil-based lubricants and greases, hydraulic fluids, hydrocarbons, and water just like NBR. HNBR is more resistant to heat, o-zone, and aging than NBR. The material's temperature range is from -30C to +100C [-22F to +212F].
S	SILICONE	This material is capable of operating in a wide temperature range and has excellent resistance to o-zone, water, weathering, and aging. This material is generally not resistant to fuels, oils, steams, acids, or high pressures. This material's temperature range is from -65C to +250C [-85F to +482F].
F	FLUROSILICONE	This material is far more resistant to oils and fuels than other silicones. The temperature range, however, is limited from -73C to +177C [-100F to +350F].
G	GRAPHOIL	Graphoil is chemically resistant to attack from nearly all organic and inorganic fluids with exception of highly oxidizing chemicals and highly concentrated oxidizing mineral acids. The material is good up to +538C [+1000F] as well as at cryogenic temperatures.
U	FLUORSINT	This material contains a mica filler and offers superb mechanical properties such as resistance to abrasion, wear, and extrusion. It is ideal for high pressure applications and offers low co-efficient of friction. Its temperature range is from -46C to +343C [-50F to +650F].

**Note:** Additional options available upon request

## Optional Seat Selections

Code	Material	Description
D	DEVLON	Devlon is a polyamide with additives which allow it to perform at -46C to +121C [-50F to +250F]. This material covers a wide range of applications while having excellent wear properties, low friction, and improved impact strength.
M-S	METAL (STELLITE)	Metal seats hardfaced with Stellite 6 are recommended for use in high temperature fluid and gas applications. The temperature range of the material allows it to get up to the maximum temperature of the valve body material.
M-TC	METAL (TUNGSTEN CARBIDE)	Metal seats hardfaced with Tungsten Carbide are recommended for use in high temperature fluid and gas applications. The temperature range of the material allows it to get up to the maximum temperature of the valve body material.
N	NYLON	Nylon is offered for high pressure applications. The material is ideal for use in high pressure air, oil, and other gas media but is not suitable for strong oxidizing agents. The temperature range of this material is -34C to +121C [-29F to +250F].
O	NOVA	This Teflon based product is filled with glass amorphous carbon powder and graphite. It has a lower thermal contraction-expansion than PTFE and is ideal for steam or thermal fluid applications up to +288C [+550F].
P	PEEK	PEEK offers a unique combination of chemical, mechanical, and thermal properties. This material is excellent for high temperatures up to +260C [+500F].
T	TEFLON (VIRGIN PTFE)	PTFE is a fluorocarbon-based polymer. This material has excellent chemical resistance and co-efficient of friction. The material is not recommended for liquid alkalis and fluorine. Its temperature range is good from -34C to +204C [-30F to +400F].
K	PCTFE	Kel-F is a fluorocarbon based polymer offering a unique combination of physical and mechanical characteristics such as non-flamability, chemical resistance, and near zero moisture absorption. The temperature range of this material is from -240C to +204C [-400F to +400F].
R	RPTFE	PTFE's mechanical properties are enhanced by adding a percentage of filler material to provide improved strength, stability, and wear resistance. The temperature range of this material is -46C to +232C [-50F to +450F].

**Note:** Additional options available upon request

# Seal & Seat Pressure Temperature Chart

This chart depicts pressure and temperature ratings for common plastics and elastomers used in SCV Valve products.

## SCV VALVE SOFT GOOD CHEMICAL COMPATIBILITY

	SEAL MATERIAL			SEAT MATERIAL			
	Viton	HNBR	Kalrez	RTFE	Nylon	Devlon	PEEK
Amines	X	X	●	●	X	X	●
Ammonia	X	X	●	●	●	●	●
Butane	●	●	●	●	●	●	●
Carbon Dioxide	●	●	●	●	●	●	●
Crude Oil	●	●	●	●	●	●	●
Ethane	●	●	●	●	X	X	●
Ethylene	●	●	●	●	●	●	●
Glycol	●	●	●	●	●	X	●
Hydrocarbon	●	●	●	●	●	●	●
Hydrogen	●	●	●	●	●	●	●
Jet Fuel	*	*	●	●	X	X	●
Methane	●	●	●	●	●	●	●
Natural Gas	●	●	●	●	●	●	●
Nitrogen	●	●	●	●	●	●	●
Propane	●	●	●	●	●	●	●
Propylene	●	X	●	●	●	●	●

\* Viton OK for JP-3/4/5/6/8/9/10. \* HNBR OK for JP-3/4/5/6.

## PRESSURE TEMPERATURE CHART

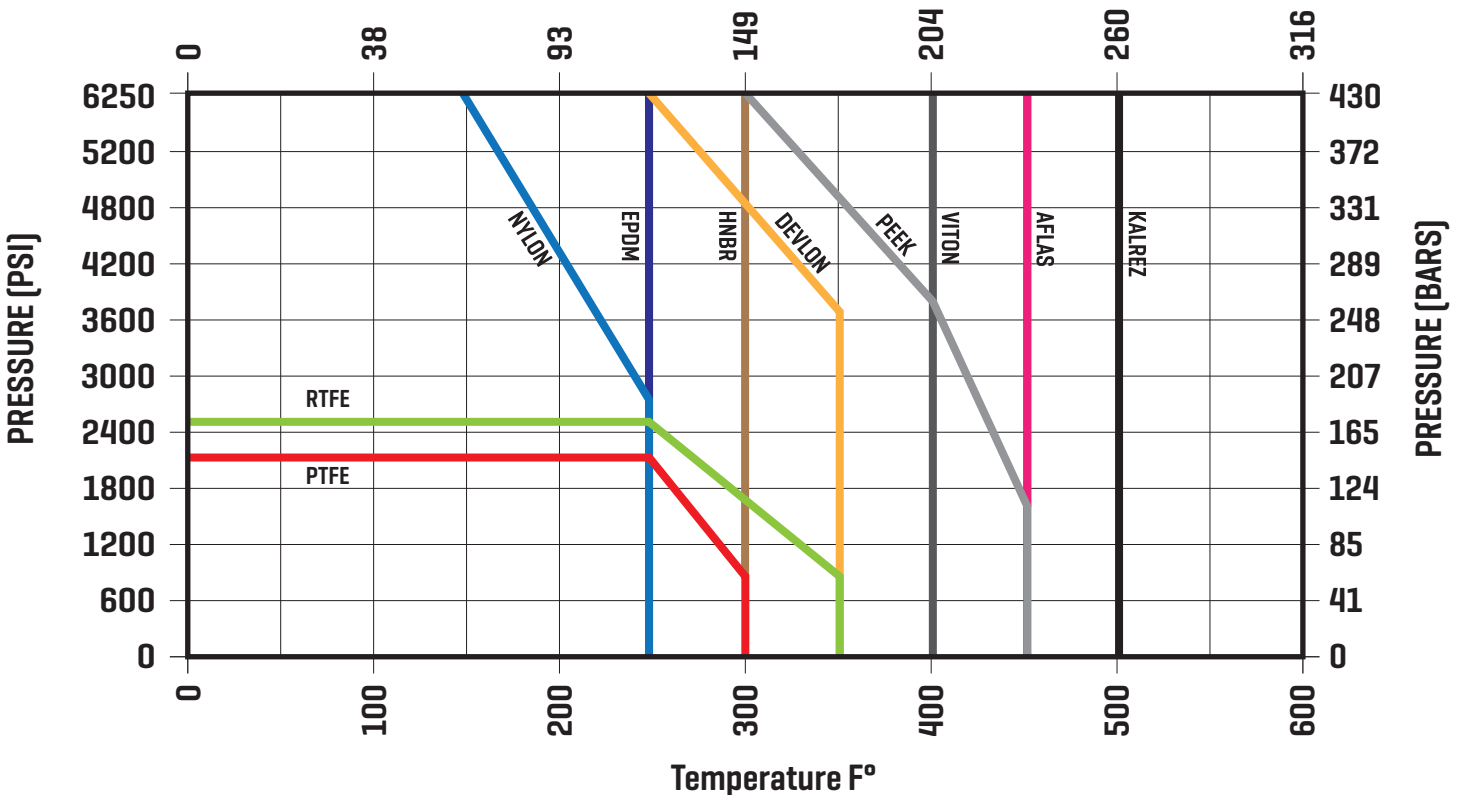

# Valve ID Tag & Valve Markings Identification

## Valve ID Tag

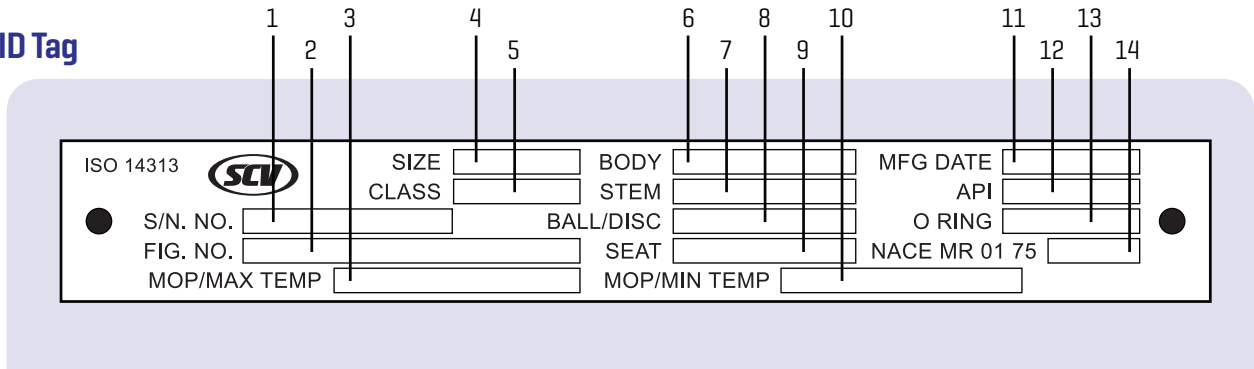

No.	Figure Number Code	Description
1	Serial Number	Identifies certified manufacturers serial number
2	Figure Number	Identifies the detailed valve configuration (valve type, bore size, pressure class, materials, etc.)
3	MOP/Max. Temp.	Identifies the maximum operating pressure in PSI and maximum operating temperature in Fahrenheit
4	Size	Identifies bore size
5	Pressure Class	Identifies pressure classifications per API requirements
6	Body Material	Identifies body metal material composition (A105, WCB, F51, CF8M, etc.)
7	Stem Material	Identifies stem material composition (A105, 410SS, 17-4pH, etc.)
8	Ball/Disc Material	Identifies ball/disc material composition (A105, 316SS, ENP, etc.)
9	Seat Material	Identifies seat material composition (PEEK, Teflon, Nylon, etc.)
10	MOP/Min. Temp.	Identifies the maximum operating pressure in PSI and minimum operating temperature in Fahrenheit
11	Manufacturing Date	Identifies the date the valve manufacturing completion date
12	API Conformance	Identifies API conformance (600, 6D, 6A, etc.)
13	O Ring	Identifies the O Ring material composition (Viton, Viton GLT, etc.)
14	NACE MR 01 75	Identifies corrosion resistance

## Valve Markings

No.	Valve ID Components
1	Tag
2	Brand
3	Size
4	Pressure Class
5	Body Material
6	Heat Number

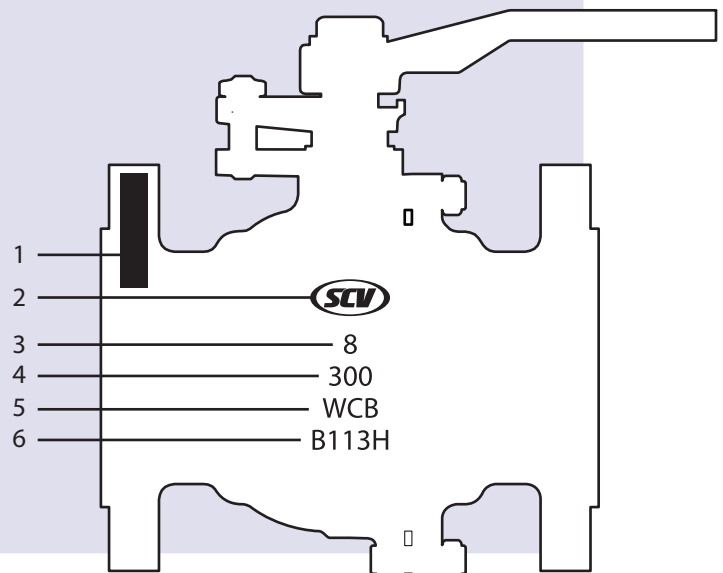

**Note:** SCV reserves the right to modify our products for improvement without prior notice.



## 1-Piece Flanged Floating Ball Valves Reduced Port Class: 150 - 300/Sizes: 1-1/2" - 12"



Design and Manufacturing Standards	
Basic Design	ANSI/ASME B16.34, conforms to API 6D
Face-to-Face Dimension	ANSI/ASME B16.10
Flange End Dimension	ANSI/ASME B16.5
Inspection & Testing	API 598
Fire Safe Design	API 607/BS 6755



# 1-Piece Flanged Floating Ball Valves - Reduced Port

[ Expanded View ]

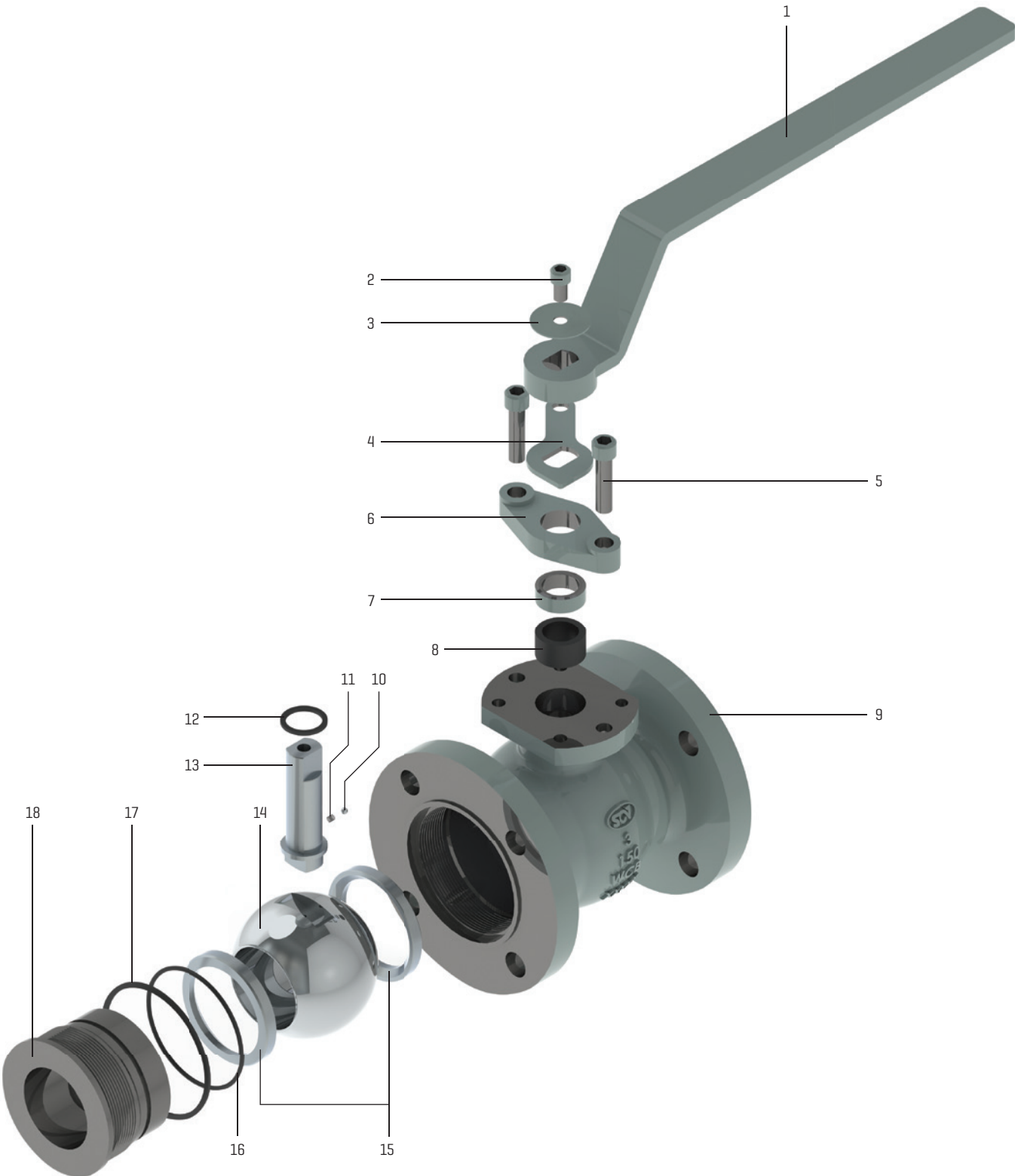

# 1-Piece Flanged Floating Ball Valves - Reduced Port ■■■■■■■■■■

## [ Bill of Materials & Features ]

### Bill of Materials

No	Name of Part	Material
1	Handle	Carbon Steel
2	SHCS	ASTM A193 - BB
3	Name Plate	304 SS
4	Handle Stop	304 SS
5	SHCS	ASTM A193 - BB
6	Gland Flange	ASTM A351 - CF8
7	Gland	ASTM A351 - CF8
8	Gland Packing	Graphite
9	Body	ASTM A216 - WCB
10	Ball	ASTM A276 - 316
11	Anti- Static Spring	ASTM A580 - 316
12	Thrust Washer	RTFE
13	Stem	ASTM A276 - 316
14	Ball	ASTM A351 - CF8
15	Seat	PTFE
16	O-Ring	VITON
17	Gasket	316 SS + Graphite
18	Cap	ASTM A216 - WCB

**Note:** Additional materials available upon request

### Features

1-piece body design with flanged ends for fast installation
Solid ball construction provides structural integrity and minimizes flow turbulence
Mounting pad complies with ISO 5211 for ease and interchangeability of actuation
Anti-static devices
Basic design complies with ASME/ANSI B16.34
Flanged ends comply with ASME/ANSI B16.5
Face-to-face dimensions comply with ASME/ANSI B16.10
Fire Safe Design: API 607/BS 6755
NACE MR 01-75
Hydrostatic and pneumatic test are conducted per standard, API 6D
The finishes of contact face of end flanges are machined 125 - 250 AARH with serrated spiral finish

# 1-Piece Flanged Floating Ball Valves - Reduced Port

Size: 1-1/2" - 12"  
Class: 150

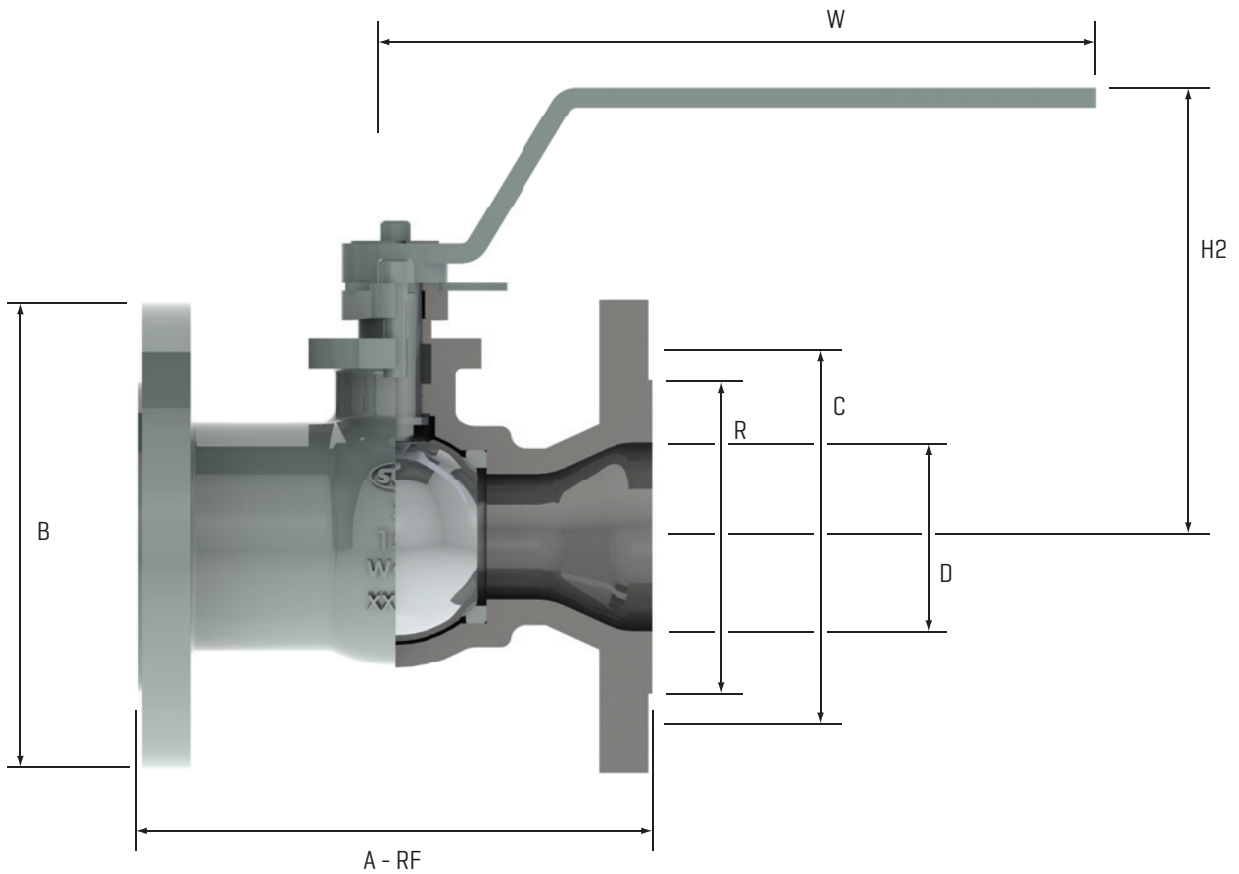

CLASS 150	Size		Bore	End - to - End	Raised Face OD	Bolt Circle Diameter	Flange OD	Center - to - Top	Lever Length	Weights LBS/KG
			D	A - RF	R	C	B	H2	W	
	IN	1.5*	1	6.5	2.88	3.88	5.00	4	9.06	13
	MM	40	25	165	73	99	127	102	230	6
	IN	2*	1.5	7	3.62	4.75	6.00	5	9.06	19
	MM	50	38	178	92	121	152	127	230	9
	IN	2.5*	2	7.5	4.12	5.50	7.00	5.6	15.75	30
	MM	65	51	191	105	140	178	142	400	14
	IN	3*	2.32	8	5.00	6.00	7.50	6.1	15.75	38
	MM	80	59	203	127	152	191	154	400	17
	IN	4*	3	9	6.19	7.50	9.00	6.7	18.11	66
	MM	100	76	229	157	191	229	170	460	30
	IN	6*	4	10.5	8.50	9.50	11.00	8.1	21.65	149
	MM	150	102	266.7	216	241	279	206	550	68
	IN	8	5.67	11.5	10.62	11.75	13.50	10.9	39.37	228
	MM	200	144	292	270	299	343	278	1000	103
	IN	10	7.32	13	12.75	14.25	16.00	12.8	39.37	455
	MM	250	186	330	324	362	406	325	1000	206
	IN	12	8.66	14	15	17	19	16.5	39.37	638
	MM	300	220	356	381	432	483	419	1000	289

\* = Lever operated



# 1-Piece Flanged Floating Ball Valves - Reduced Port

Size: 1-1/2" - 10"  
 Class: 300

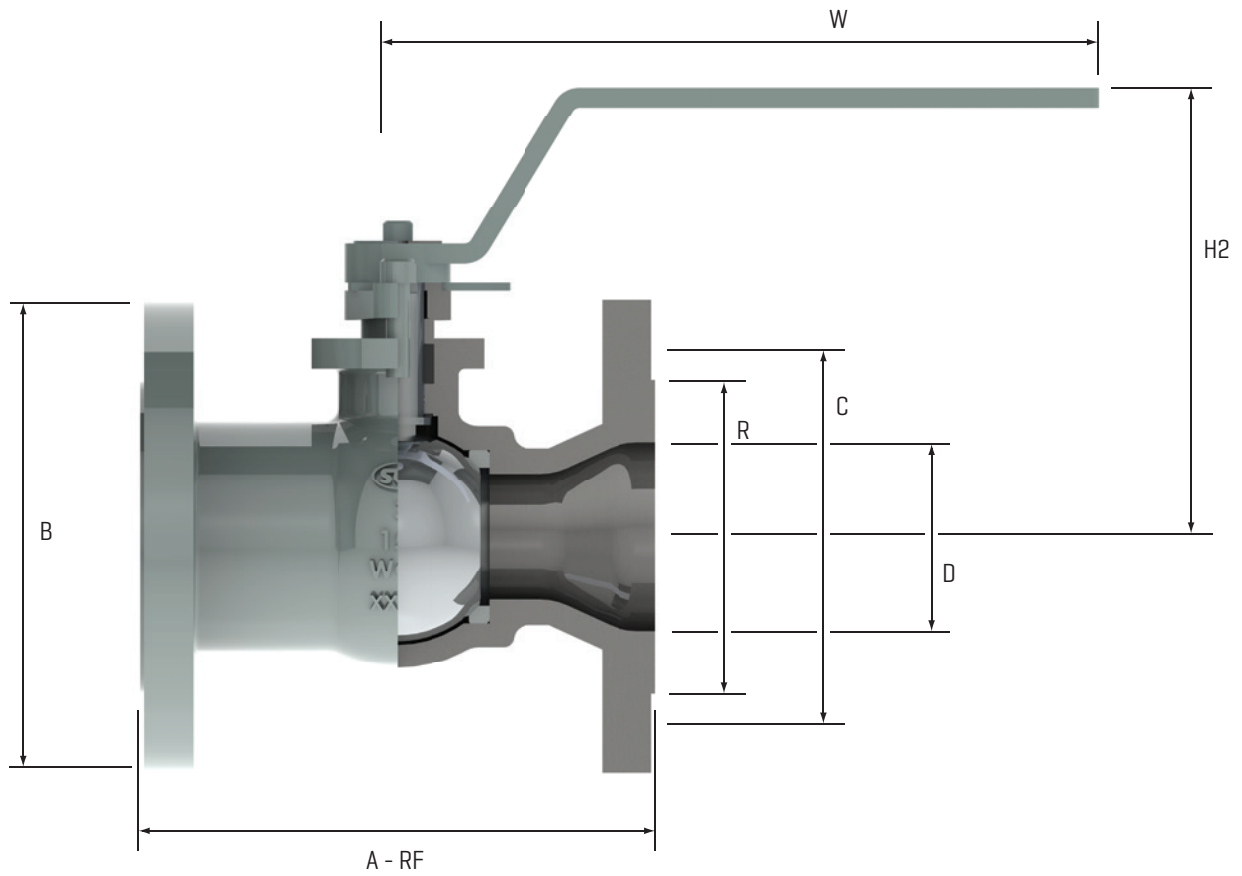

CLASS 300	Size		Bore	End - to - End	Raised Face OD	Bolt Circle Diameter	Flange OD	Center - to - Top	Lever Length	Weights LBS/KG
			D	A - RF	R	C	B	H2	W	
	IN	1.5*	1	7.5	2.88	4.50	6.12	4	9.06	21
	MM	40	25	191	73	114	155	102	230	10
	IN	2*	1.5	8.5	3.62	5.00	6.50	5	9.06	29
	MM	50	38	216	92	127	165	127	230	13
	IN	3*	2.32	11.14	5.00	6.62	8.25	6.1	15.75	60
	MM	80	59	283	127	168	210	154	400	27
	IN	4*	3	12	6.19	7.88	10.00	6.7	18.11	129
	MM	100	76	305	157	200	254	170	460	59
	IN	6*	4	15.87	8.50	10.62	12.50	8.1	21.65	182
	MM	150	102	403	216	270	318	206	550	83
	IN	8	5.67	16.5	10.62	13.00	15.00	10.9	39.37	290
	MM	200	144	419	270	330	381	277	1000	132
	IN	10	7.32	18	12.75	15.25	17.50	12.8	39.37	490
	MM	250	186	459	324	387	445	325	1000	222

\* = Lever operated



**SCV VALVE**

## 2-Piece Flanged Floating Ball Valves Full Port Class: 150 - 1500/Sizes: 1/2" - 12"



Design and Manufacturing Standards	
Basic Design	ANSI/ASME B16.34, conforms to API 6D
Face-to-Face Dimension	ANSI/ASME B16.10
Flange End Dimension	ANSI/ASME B16.5
Inspection & Testing	API 598
Fire Safe Design	API 607/BS 6755

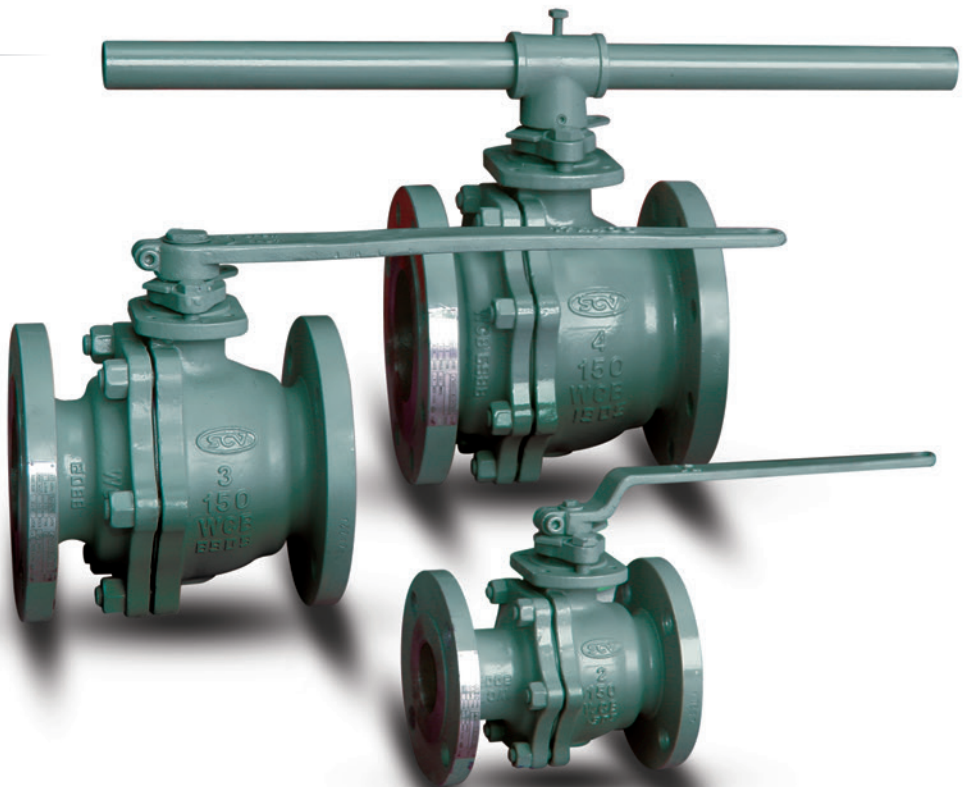



## 2-Piece Flanged Floating Ball Valves - Full Port ■■■■■■■■■■

### [ Bill of Materials & Features ]

#### Bill of Materials

No	Name of Part	Material
1	SHCS	304 SS
2	Name Plate	304 SS
3	Handle	Carbon Steel
4	Handle Stop	304 SS
5	SHCS	304 SS
6	Gland Flange	ASTM A351 - CF8
7	Gland	ASTM A351 - CF8
8	Stem Packing	Graphite
9	Body	ASTM A216 - WCB
10	Stud	GR. B7
11	Seat	PTFE
12	Body Gasket	316 + Graphite
13	Body End Cap	ASTM A216 - WCB
14	Heavy Hex Nut	GR. 2H
15	Ball	ASTM A351 - CF8M/316
16	Stem	ASTM A276-316
17	Anti- Static Spring	316 SS
18	Ball	316 SS
19	Thrust Washer	PTFE

**Note:** Additional materials available upon request

#### Features

Split body design with flanged ends for fast installation, in-line maintenance and rebuilding
Solid ball construction provides structural integrity and minimizes flow turbulence
Mounting pad complies with ISO 5211 for ease and interchangeability of actuation
Bottom-loaded blow-out proof stem
Investment cast body & end cap on sizes 1/2" to 4". Sand cast body & end cap on sizes 5" to 10"
Body joint is designed to prevent excessive compression of valve internals, resulting in a consistent and low operating torque
Basic design complies with ASME/ANSI B16.34
Flanged ends comply with ASME/ANSI B16.5
Face-to-face dimensions comply with ASME/ANSI B16.10
Tested according to ANSI/ASME B16.34 & API 598
Fire Tested to API 607/BS 6577

# 2-Piece Flanged Floating Ball Valves - Full Port

Size: 1/2" - 12"  
Class: 150

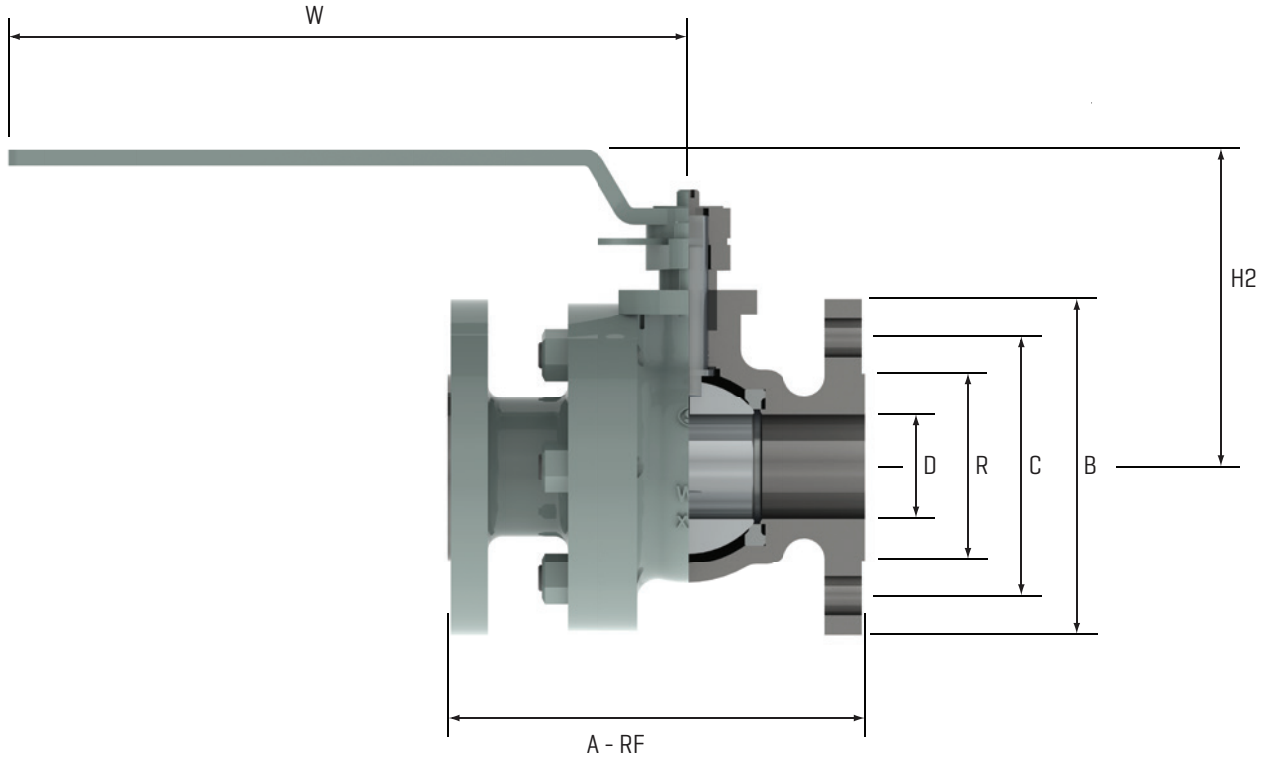

CLASS 150	Size		Bore	End - to - End	Raised Face OD	Bolt Circle Diameter	Flange OD	Center - to - Top	Lever Length	Weights LBS/KG
			D	A - RF	R	C	B	H2	W	
	IN	.5*	.5	4.25	1.38	2.38	3.50	3.15	5.12	5
	MM	15	13	108	35	61	89	80	130	2.3
	IN	.75*	.75	4.62	1.69	2.75	3.88	3.27	5.12	7
	MM	20	19	117	43	70	99	83	130	3
	IN	1*	1	5.00	2.00	3.12	4.25	3.82	6.30	10
	MM	25	25	127	51	79	108	97	160	4.5
	IN	1.5*	1.5	6.50	2.88	3.88	5.00	4.37	9.06	15
	MM	40	38	165	73	99	127	111	230	7
	IN	2*	2	7.00	3.62	4.75	6.00	4.65	9.06	21
	MM	50	51	178	92	121	152	118	230	9.5
	IN	2.5*	2.5	7.50	4.12	5.50	7.00	5.67	15.75	33
	MM	65	64	191	105	140	178	144	400	15
	IN	3*	3	8.00	5.00	6.00	7.50	6.06	15.75	42
	MM	80	76	203	127	152	191	154	400	19
	IN	4*	4	9.00	6.19	7.50	9.00	6.85	18.11	73
	MM	100	102	229	157	191	229	174	460	33
	IN	6*	6	15.50	8.50	9.50	11.00	9.45	21.65	165
	MM	150	152	394	216	241	279	240	550	75
	IN	8	8	18.00	10.62	11.75	13.50	11.81	39.37	253
	MM	200	203	457	270	299	343	300	1000	115
	IN	10	10	21.00	12.75	14.25	16.00	13.98	39.37	506
	MM	250	254	533	324	362	406	355	1000	230
	IN	12	12	21	16.00	17.00	19.00	18.9	39.37	864
	MM	300	305	533	406.4	431.8	482.6	480	1000	392

\* = Lever operated

# 2-Piece Flanged Floating Ball Valves - Full Port

Size: 1/2" - 10"  
Class: 300

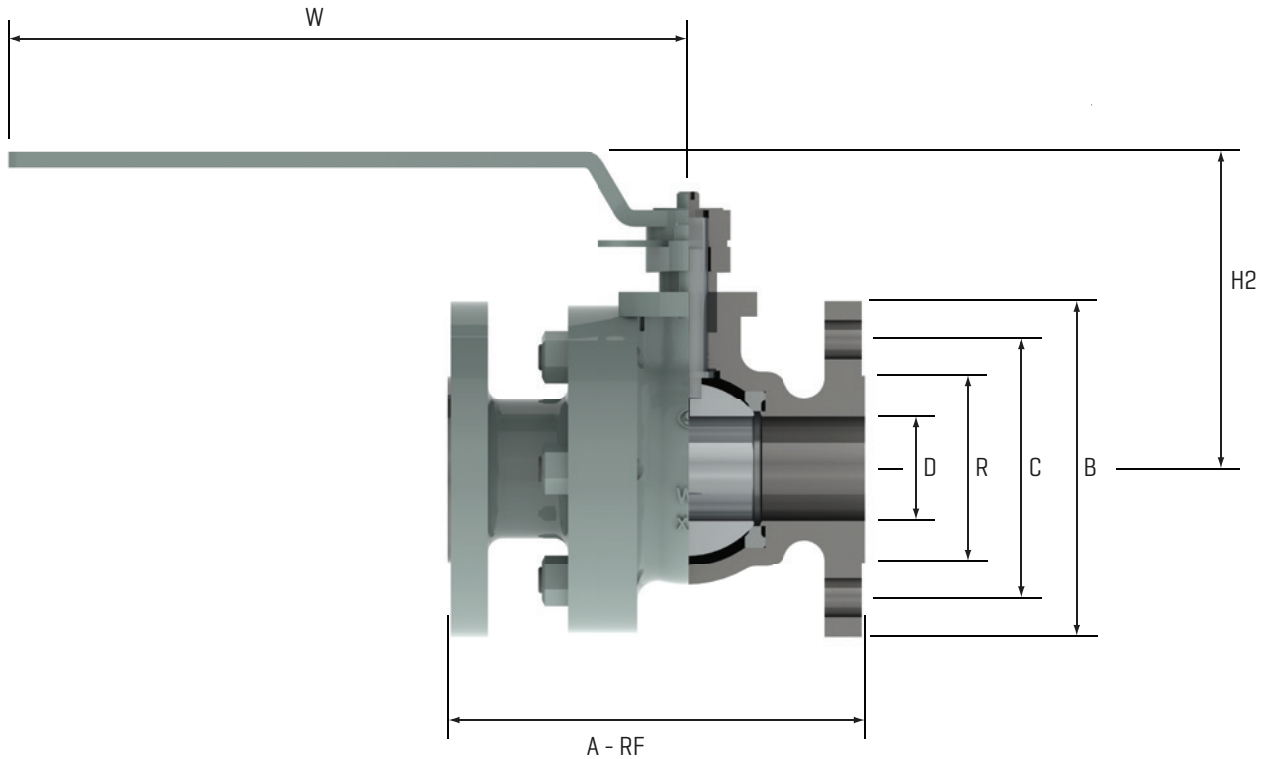

CLASS 300	Size		Bore	End - to - End	Raised Face OD	Bolt Circle Diameter	Flange OD	Center - to - Top	Lever Length	Weights LBS/KG
			D	A - RF	R	C	B	H2	W	
	IN	.5*	0.59	5.50	1.38	2.62	3.75	2.48	5.12	5.5
	MM	15	15	140	35	67	95	63	130	2.5
	IN	.75*	.079	6.00	1.69	3.25	4.62	2.68	5.12	8
	MM	20	20	152	43	83	117	68	130	3.6
	IN	1*	1.00	6.50	2.00	3.5	4.88	2.99	6.30	12
	MM	25	25	165	51	89	124	76	160	5.5
	IN	1.5*	1.57	7.50	2.88	4.50	6.12	3.46	9.06	23
	MM	40	40	191	73	114	155	88	230	10.5
	IN	2*	1.97	8.50	3.62	5.00	6.50	3.70	9.06	32
	MM	50	50	216	92	127	165	94	230	14.5
	IN	2.5*	2.56	9.50	4.12	5.88	7.50	4.53	15.75	52
	MM	65	65	241	105	149	191	115	400	23.5
	IN	3*	3.15	11.12	5.00	6.62	8.25	4.72	15.75	66
	MM	80	80	282	127	168	210	120	400	30
	IN	4*	3.94	12.00	6.19	7.88	10.00	7.68	18.11	143
	MM	100	100	305	157	200	254	195	460	65
	IN	6*	5.91	16.00	8.50	10.62	12.50	9.45	21.65	209
	MM	150	150	403	216	270	318	240	550	95
	IN	8	7.87	20.00	10.62	13.00	15.00	11.81	39.37	330
	MM	200	200	502	270	330	381	300	1000	150
	IN	10	9.84	22.38	12.75	15.25	17.50	13.98	39.37	550
	MM	250	250	568	324	387	445	355	1000	250

\* = Lever operated

# 2-Piece Flanged Floating Ball Valves - Full Port

Size: 1/2" - 6"  
Class: 600

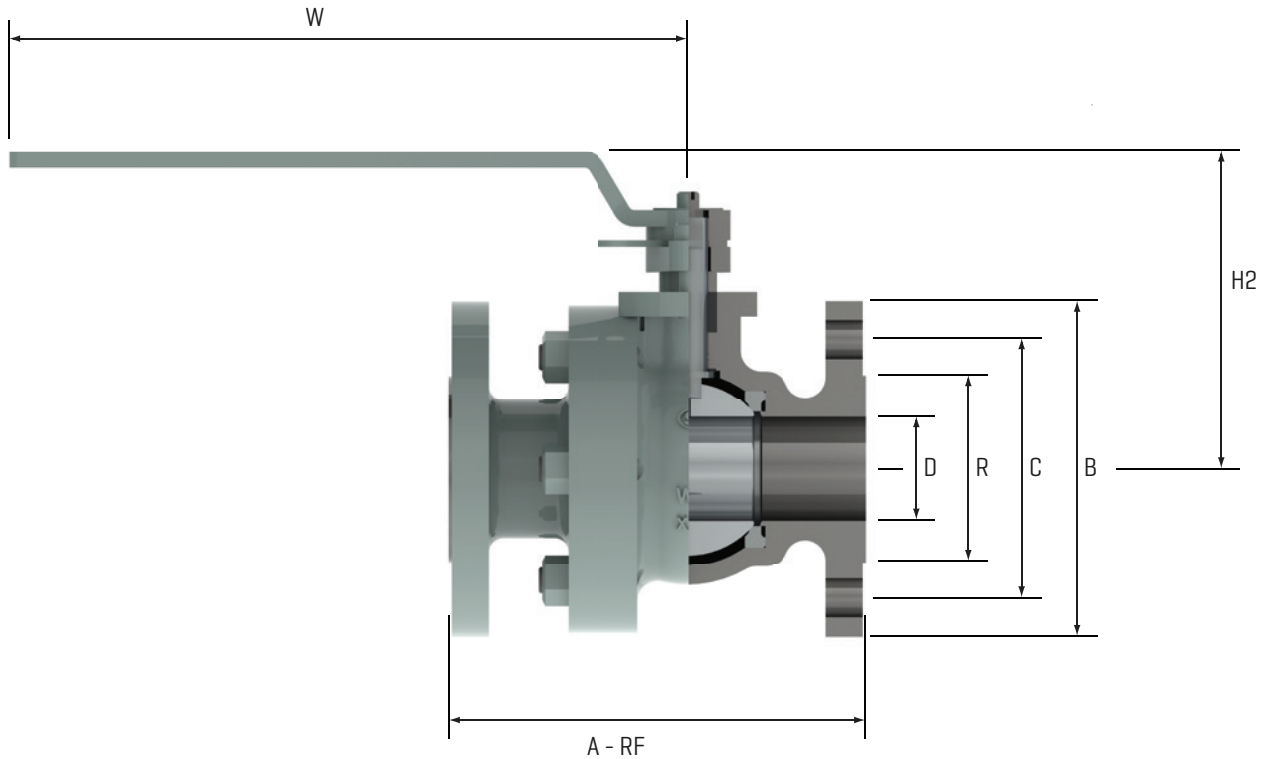

CLASS 600	Size		Bore	End - to - End	Raised Face OD	Bolt Circle Diameter	Flange OD	Center - to - Top	Lever Length	Weights LBS/KG
			D	A - RF	R	C	B	H2	W	
	IN	.5*	.51	6.5	/	2.63	3.74	3.54	4.72	12
	MM	15	13	165	/	66.7	95	90	120	5
	IN	.75*	.75	7.5	/	3.25	4.53	3.66	5.52	18
	MM	20	19	190	/	82.6	115	93	140	8
	IN	1*	1	8.5	/	3.50	4.92	3.94	6.49	25
	MM	25	25	210	/	88.9	125	100	165	11
	IN	1.5*	1.5	9.5	/	4.50	6.10	4.96	7.87	30
	MM	40	38	241	/	114.3	155	126	200	14
	IN	2*	2	11.5	3.62	5.00	6.50	5.31	9.06	40
	MM	50	51	292	92	127	165	135	230	18
	IN	3*	3	14.00	5.00	6.62	8.25	6.7	15.75	75
	MM	80	76	356	127	168	210	170	400	34
	IN	4*	4	17.00	6.19	8.5	10.75	8.1	18.11	165
	MM	100	102	432	157	200	254	206	460	75
	IN	6	6	22.00	8.50	11.5	14	13.1	21.65	221
	MM	150	152	559	216	270	318	331	550	101

\* = Lever operated

# 2-Piece Flanged Floating Ball Valves - Full Port

Size: 1/2" - 2"  
Class: 1500

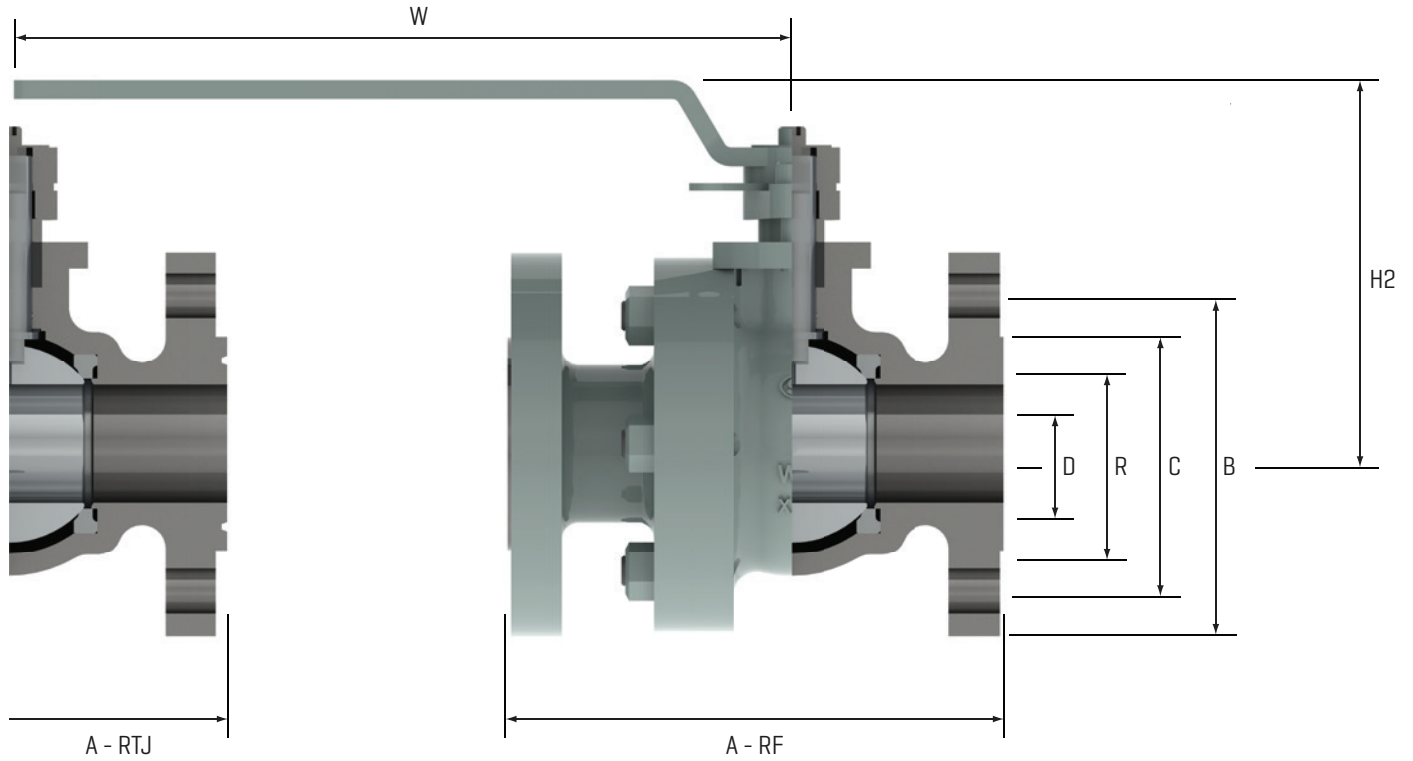

CLASS 1500	Size		Bore	End - to - End		Raised Face OD	Bolt Circle Diameter	Flange OD	Center - to - Top	Lever Length	Weights LBS/KG
			D	A - RF	A - RTJ	R	C	B	H2	W	
	IN	.5*	.51	8.5	8.6	/	3.3	4.7	3.9	9.06	14
	MM	13	13	216	219	/	83	120	99	230	6
	IN	.75*	.75	9.00	9.1	/	3.5	5.2	4	9.06	20
	MM	19	19	229	231	/	89	130	102	230	9
	IN	1*	1	10.00	10.0	/	4.1	5.9	4.5	9.06	29
	MM	25	25	254	257	/	102	150	115	230	13
	IN	1.5*	1.5	12.00	12.2	/	4.9	7.1	5.7	9.06	40
	MM	38	38	305	308	/	124	180	144	230	18
	IN	2*	1.97	14.48	14.6	3.62	5.00	6.50	6.29	9.06	48
	MM	51	50	368	371	92	127	165	160	230	22

\* = Lever operated



# 1 & 2-Piece Flanged Floating Ball Valves Full & Reduced Port

## Flow Coefficients Cv Values and Opening Torques for Soft Seats

### Flow Coefficients Cv Values

The Flow Coefficiency (Cv) of a valve is the rate of gallons per minute of water at 60° F through a fully opened valve at a pressure drop of 1 PSI across the valve.

Size	150		300		600		1500
	Full Port	Reduced Port	Full Port	Reduced Port	Full Port	Reduced Port	Full Port
.5	26	/	26	/	21	/	14
.75	61	/	61	/	44	/	34
1	113	/	113	/	75	/	60
1.5	270	106	270	106	239	/	180
2	470	153	470	156	405	/	305
2.5	740	276	/	/	590	/	/
3	1,250	317	1,100	361	745	/	/
4	2,250	449	2,150	533	1830	/	/
6	5,200	899	5,150	1,039	4570	/	/
8	9,550	1,180	9,450	1,402	/	/	/
10	15,050	3,277	15,050	3,277	/	/	/
12	23,050	4,350	/	/	/	/	/

### Opening Torques for Soft Seats

The operating torques are in foot pounds and are calculated based on soft seats, normal temperatures, and clean media.

Size	ISO 5211	150		300		600		1500
		Full Port	Reduced Port	Full Port	Reduced Port	Full Port	Reduced Port	Full Port
.5	F03/F04	5	/	7	/	13	/	26
.75		7	/	12	/	18	/	37
1	F05/F06	12	/	18	/	30	/	74
1.5		26	26	37	37	67	/	133
2	F10	37	37	52	52	81	/	199
2.5		59	59	74	/	122	/	/
3	F10/F12	89	89	118	118	221	/	/
4		133	133	207	207	443	/	/
6		177	177	738	738	1438	/	/
8		F14	708	708	1549	1549	/	/
10	F16	1328	1328	2508	2508	/	/	/
12		2089	2089	/	/	/	/	/

#### Notes

1	Torques may change with different mediums and trim materials.
2	All valves are at normal temperature with PTFE seats for Class 150 and 300 lbs. Nylon seats for class 600 through 1500.
3	All torques are at maximum differential. Safety factor not included.

# Pressure Temperature Ratings - ASME B16.34

Note: Pressures in PSI

150	Temp. F	A105	WCB	LF2	WCC	LCB	WC6	LCC	C5	C12	C12A	316	CF8M	F51	F53
	-20 to 100	285	285	285	290	265	290	290	290	290	290	290	275	275	290
200	260	260	260	260	255	260	260	260	260	260	260	235	235	260	260
300	230	230	230	230	230	230	230	230	230	230	230	215	215	230	230
400	200	200	200	200	200	200	200	200	200	200	200	195	195	200	200
500	170	170	170	170	170	170	170	170	170	170	170	170	170	170	170
600	140	140	140	140	140	140	140	140	140	140	140	140	140	140	140
650	125	125	125	125	125	125	125	125	125	125	125	125	125	125	125
700	110	110	110	110	110	110	110	110	110	110	110	110	110	110	110
750	95	95	95	95	95	95	95	95	95	95	95	95	95	95	95
800	80	80	80	80	80	80	80	80	80	80	80	80	80	/	/
850	65	65	65	65	65	65	65	65	65	65	65	65	65	/	/
900	50	50	50	50	50	50	50	50	50	50	50	50	50	/	/
950	35	35	35	35	35	35	35	35	35	35	35	35	35	/	/
1000	20	20	20	20	20	20	20	20	20	20	20	20	20	/	/
1050	/	/	/	/	/	/	20	/	20	20	20	20	20	/	/
1100	/	/	/	/	/	/	20	/	20	20	20	20	20	/	/
1150	/	/	/	/	/	/	20	/	20	20	20	20	20	/	/
1200	/	/	/	/	/	/	15	/	15	20	20	20	20	/	/
1250	/	/	/	/	/	/	/	/	/	/	/	20	20	/	/
1300	/	/	/	/	/	/	/	/	/	/	/	20	20	/	/
1350	/	/	/	/	/	/	/	/	/	/	/	20	20	/	/
1400	/	/	/	/	/	/	/	/	/	/	/	20	20	/	/
1450	/	/	/	/	/	/	/	/	/	/	/	20	20	/	/
1500	/	/	/	/	/	/	/	/	/	/	/	15	15	/	/

300	Temp. F	A105	WCB	LF2	WCC	LCB	WC6	LCC	C5	C12	C12A	316	CF8M	F51	F53
	-20 to 100	740	740	740	750	695	750	750	750	750	750	750	720	720	750
200	680	680	680	750	660	750	750	750	750	750	750	620	620	745	745
300	655	655	655	730	640	720	730	730	730	730	730	560	560	665	665
400	635	635	635	705	615	695	705	705	705	705	705	515	515	615	615
500	605	605	605	665	585	665	665	665	665	665	665	480	480	580	580
600	570	570	570	605	550	605	605	605	605	605	605	450	450	555	555
650	550	550	550	590	535	590	590	590	590	590	590	440	440	545	545
700	530	530	530	555	510	570	555	570	570	570	570	435	435	540	540
750	505	505	505	505	475	530	505	530	530	530	530	425	425	530	530
800	410	410	410	410	390	510	410	510	510	510	510	420	420	/	/
850	320	320	320	320	300	485	320	485	485	485	485	420	420	/	/
900	230	230	230	225	200	450	225	375	450	450	450	415	415	/	/
950	135	135	135	135	135	320	135	275	375	385	385	385	385	/	/
1000	85	85	85	85	85	215	85	200	255	365	365	365	365	/	/
1050	/	/	/	/	/	145	/	145	170	360	360	160	160	/	/
1100	/	/	/	/	/	95	/	100	115	300	300	305	305	/	/
1150	/	/	/	/	/	65	/	60	75	225	225	235	235	/	/
1200	/	/	/	/	/	40	/	35	50	145	145	185	185	/	/
1250	/	/	/	/	/	/	/	/	/	/	/	145	145	/	/
1300	/	/	/	/	/	/	/	/	/	/	/	115	115	/	/
1350	/	/	/	/	/	/	/	/	/	/	/	95	95	/	/
1400	/	/	/	/	/	/	/	/	/	/	/	75	75	/	/
1450	/	/	/	/	/	/	/	/	/	/	/	60	60	/	/
1500	/	/	/	/	/	/	/	/	/	/	/	40	40	/	/

# Pressure Temperature Ratings - ASME B16.34

Note: Pressures in PSI

Temp. F	A105	WCB	LF2	WCC	LCB	WC6	LCC	C5	C12	C12A	316	CF8M	F51	F53
	-20 to 100	1480	1480	1480	1500	1395	1500	1500	1500	1500	1500	1440	1440	1500
200	1360	1360	1360	1500	1320	1500	1500	1500	1500	1500	1240	1240	1490	1490
300	1310	1310	1310	1455	1275	1445	1455	1455	1455	1455	1120	1120	1335	1335
400	1265	1265	1265	1405	1230	1385	1405	1410	1410	1410	1025	1025	1230	1230
500	1205	1205	1205	1330	1175	1330	1330	1330	1330	1330	995	995	1160	1160
600	1135	1135	1135	1210	1105	1210	1210	1210	1210	1210	900	900	1115	1115
650	1100	1100	1100	1175	1065	1175	1175	1175	1175	1175	885	885	1095	1095
700	1060	1060	1060	1110	1025	1135	1110	1135	1135	1135	870	870	1085	1085
750	1015	1015	1015	1015	955	1065	1015	1065	1065	1065	855	855	1065	1065
800	825	825	825	825	780	1015	825	1015	1015	1015	845	845	/	/
850	640	640	640	640	595	975	640	975	975	975	835	835	/	/
900	460	460	460	445	405	900	445	745	900	900	830	830	/	/
950	275	275	275	275	275	640	275	550	755	775	775	775	/	/
1000	170	170	170	170	170	430	170	400	505	725	725	725	/	/
1050	/	/	/	/	/	290	/	290	345	720	720	720	/	/
1100	/	/	/	/	/	190	/	200	225	605	610	610	/	/
1150	/	/	/	/	/	130	/	125	150	445	475	475	/	/
1200	/	/	/	/	/	80	/	70	105	290	370	370	/	/
1250	/	/	/	/	/	/	/	/	/	/	295	295	/	/
1300	/	/	/	/	/	/	/	/	/	/	235	235	/	/
1350	/	/	/	/	/	/	/	/	/	/	190	190	/	/
1400	/	/	/	/	/	/	/	/	/	/	150	150	/	/
1450	/	/	/	/	/	/	/	/	/	/	115	115	/	/
1500	/	/	/	/	/	/	/	/	/	/	85	85	/	/

Temp. F	A105	WCB	LF2	WCC	LCB	WC6	LCC	C5	C12	C12A	316	CF8M	F51	F53
	-20 to 100	2220	2220	2220	2250	2090	2250	2250	2250	2250	2250	2160	2160	2250
200	2035	2035	2035	2250	1980	2250	2250	2250	2250	2250	1860	1860	2230	2230
300	1965	1965	1965	2185	1915	2165	2185	2185	2185	2185	1680	1680	2000	2000
400	1900	1900	1900	2110	1845	2080	2110	2115	2115	2115	1540	1540	1845	1845
500	1810	1810	1810	1995	1760	1995	1995	1995	1995	1995	1435	1435	1740	1740
600	1705	1705	1705	1815	1655	1815	1815	1815	1815	1815	1355	1355	1670	1670
650	1650	1650	1650	1765	1600	1765	1765	1765	1765	1765	1325	1325	1640	1640
700	1590	1590	1590	1665	1535	1705	1665	1705	1705	1705	1305	1305	1625	1625
750	1520	1520	1520	1520	1430	1595	1520	1595	1595	1595	1280	1280	1595	1595
800	1235	1235	1235	1235	1175	1525	1235	1525	1525	1525	1265	1265	/	/
850	955	955	955	955	895	1460	955	1460	1460	1460	1255	1255	/	/
900	690	690	690	670	605	1350	670	1120	1350	1350	1245	1245	/	/
950	410	410	410	410	410	955	410	825	1130	1160	1160	1160	/	/
1000	255	255	255	255	255	650	255	595	760	1090	1090	1090	/	/
1050	/	/	/	/	/	430	/	430	515	1080	1080	1080	/	/
1100	/	/	/	/	/	290	/	300	340	905	915	915	/	/
1150	/	/	/	/	/	195	/	185	225	670	710	710	/	/
1200	/	/	/	/	/	125	/	105	155	430	555	555	/	/
1250	/	/	/	/	/	/	/	/	/	/	440	440	/	/
1300	/	/	/	/	/	/	/	/	/	/	350	350	/	/
1350	/	/	/	/	/	/	/	/	/	/	290	290	/	/
1400	/	/	/	/	/	/	/	/	/	/	225	225	/	/
1450	/	/	/	/	/	/	/	/	/	/	175	175	/	/
1500	/	/	/	/	/	/	/	/	/	/	125	125	/	/

# Pressure Temperature Ratings - ASME B16.34

Note: Pressures in PSI

1500	Temp. F	A105	WCB	LF2	WCC	LCB	WC6	LCC	C5	C12	C12A	316	CF8M	F51	F53
	-20 to 100	3705	3705	3705	3750	3480	3750	3750	3750	3750	3750	3750	3600	3600	3750
200	3395	3395	3395	3750	3300	3750	3750	3750	3750	3750	3750	3095	3095	3720	3720
300	3270	3270	3270	3640	3190	3610	3640	3640	3640	3640	3640	2795	2795	3335	3335
400	3170	3170	3170	3520	3075	3465	3520	3530	3530	3530	3530	2570	2570	3070	3070
500	3015	3015	3015	3325	2930	3325	3325	3325	3325	3325	3325	2390	2390	2905	2905
600	2840	2840	2840	3025	2755	3025	3025	3025	3025	3025	3025	2255	2255	2785	2785
650	2745	2745	2745	2940	2665	2940	2940	2940	2940	2940	2940	2210	2210	2735	2735
700	2665	2665	2665	2775	2560	2840	2775	2840	2840	2840	2840	2170	2170	2710	2710
750	2535	2535	2535	2535	2385	2660	2535	2660	2660	2660	2660	2135	2135	2660	2660
800	2055	2055	2055	2055	1955	2540	2055	2540	2540	2540	2540	2110	2110	/	/
850	1595	1595	1595	1595	1490	2435	1595	2435	2435	2435	2435	2090	2090	/	/
900	1150	1150	1150	1115	1010	2245	1115	1870	2245	2245	2245	2075	2075	/	/
950	685	685	685	685	685	1591	685	1370	1885	1930	1930	1930	1930	/	/
1000	430	430	430	430	430	1080	430	995	1270	1820	1820	1820	1820	/	/
1050	/	/	/	/	/	720	/	720	855	1800	1800	1800	1800	/	/
1100	/	/	/	/	/	480	/	495	565	1510	1525	1525	1525	/	/
1150	/	/	/	/	/	325	/	310	375	1115	1185	1185	1185	/	/
1200	/	/	/	/	/	205	/	170	255	720	925	925	925	/	/
1250	/	/	/	/	/	/	/	/	/	/	735	735	735	/	/
1300	/	/	/	/	/	/	/	/	/	/	585	585	585	/	/
1350	/	/	/	/	/	/	/	/	/	/	480	480	480	/	/
1400	/	/	/	/	/	/	/	/	/	/	380	380	380	/	/
1450	/	/	/	/	/	/	/	/	/	/	290	290	290	/	/
1500	/	/	/	/	/	/	/	/	/	/	205	205	205	/	/
2500	Temp. F	A105	WCB	LF2	WCC	LCB	WC6	LCC	C5	C12	C12A	316	CF8M	F51	F53
	-20 to 100	6170	6170	6170	6250	5805	6250	6250	6250	3250	6250	6000	6000	6250	6250
200	5655	5655	5655	6250	5505	6250	6250	6250	6250	6250	6250	5160	5160	6200	6200
300	5450	5450	5450	6070	5315	6015	6070	6070	6070	6070	6070	4660	4660	5560	5560
400	5280	5280	5280	5865	5125	5775	5865	5880	5880	5880	5880	4280	4280	5120	5120
500	5025	5025	5025	5540	4885	5540	5540	5540	5540	5540	5540	3980	3980	4840	4840
600	4730	4730	4730	5040	4595	5040	5040	5040	5040	5040	5040	3760	3760	4640	4640
650	4575	4575	4575	4905	4440	4905	4905	4905	4905	4905	4905	3680	3680	4560	4560
700	4425	4425	4425	4630	4270	4730	4630	4730	4730	4730	4730	3620	3620	4520	4520
750	4230	4230	4230	4230	3970	4430	4230	4430	4430	4430	4430	3560	3560	4430	4430
800	3430	3430	3430	3430	3255	4230	3430	4230	4230	4230	4230	3520	3520	/	/
850	2655	2655	2655	2655	2485	4060	2655	4060	4060	4060	4060	3480	3480	/	/
900	1915	1915	1915	1855	1685	3745	1855	3115	3745	3745	3745	3460	3460	/	/
950	1145	1145	1145	1145	1145	3655	1145	2285	3145	3220	3220	3220	3220	/	/
1000	715	715	715	715	715	1800	715	1655	2115	3030	3030	3030	3030	/	/
1050	/	/	/	/	/	1200	/	1200	1430	3000	3000	3000	3000	/	/
1100	/	/	/	/	/	800	/	830	945	2515	2545	2545	2545	/	/
1150	/	/	/	/	/	545	/	515	630	1855	1970	1970	1970	/	/
1200	/	/	/	/	/	345	/	285	770	1200	1545	1545	1545	/	/
1250	/	/	/	/	/	/	/	/	/	/	1230	1230	1230	/	/
1300	/	/	/	/	/	/	/	/	/	/	970	970	970	/	/
1350	/	/	/	/	/	/	/	/	/	/	800	800	800	/	/
1400	/	/	/	/	/	/	/	/	/	/	630	630	630	/	/
1450	/	/	/	/	/	/	/	/	/	/	485	485	485	/	/
1500	/	/	/	/	/	/	/	/	/	/	345	345	345	/	/

# Flange Dimensions - ANSI B16.5 & B16.47

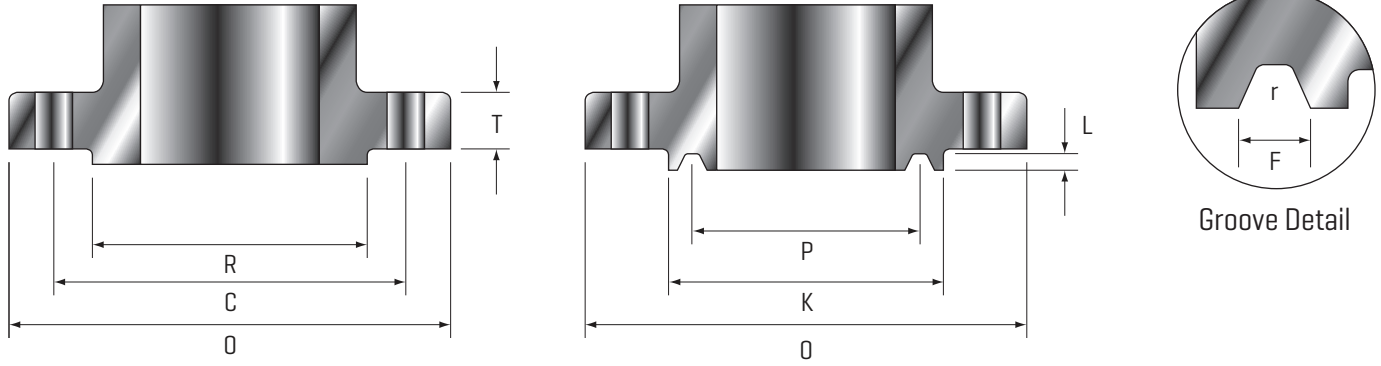

Class	Size	Flg. Dia.	Flg. Thick.	Raised Face Dia.	Drilling			Face Dia.	Ring Joint					
					Bolt Circle Dia.	# of Bolts	Hole Dia.		Pitch Dia.	Grv. Depth	Grv. Width	Btm. Radius	Ring No.	
					O	T	R	C	K	P	L	F		r
150	2	6.00	0.75	3.62	4.75	4	0.75	4.00	3.250	0.250	0.344	0.03	R22	
	2.5	7.00	0.88	4.12	5.50	4	0.75	4.75	4.000	0.250	0.344	0.03	R25	
	3	7.50	0.94	5.00	6.00	4	0.75	5.25	4.500	0.250	0.344	0.03	R29	
	4	9.00	0.94	6.19	7.50	8	0.75	6.75	5.875	0.250	0.344	0.03	R36	
	6	11.00	1.00	8.50	9.50	8	0.88	8.62	7.625	0.250	0.344	0.03	R43	
	8	13.50	1.12	10.62	11.75	8	0.88	10.75	9.750	0.250	0.344	0.03	R48	
	10	16.00	1.19	12.75	14.25	12	1.00	13.00	12.000	0.250	0.344	0.03	R52	
	12	19.00	1.25	15.00	17.00	12	1.00	16.00	15.000	0.250	0.344	0.03	R56	
	14	21.00	1.38	16.25	18.75	12	1.12	16.75	15.625	0.250	0.344	0.03	R59	
	16	23.50	1.44	18.50	21.25	16	1.12	19.00	17.875	0.250	0.344	0.03	R64	
	18	25.00	1.56	21.00	22.75	16	1.25	21.50	20.375	0.250	0.344	0.03	R68	
	20	27.50	1.69	23.00	25.00	20	1.25	23.50	22.000	0.250	0.344	0.03	R72	
	22	29.50	1.81	25.25	27.25	20	1.38	/	/	/	/	/	/	/
	24	32.00	1.88	27.25	29.50	20	1.38	28.00	26.500	0.250	0.344	0.03	R76	
	26	34.25	2.69	29.50	31.75	24	1.38	/	29.500	0.500	0.781	0.060	R93	
	28	36.50	2.81	31.50	34.00	28	1.38	/	31.500	0.500	0.781	0.060	R94	
30	38.75	2.94	33.75	36.00	28	1.38	/	33.750	0.500	0.781	0.060	R95		
32	41.75	3.19	36.00	38.50	28	1.62	/	36.000	0.562	0.906	0.060	R96		
34	43.75	3.25	38.00	40.50	32	1.62	/	38.000	0.562	0.906	0.060	R97		
36	46.00	3.56	40.25	42.75	32	1.62	/	40.250	0.562	0.906	0.060	R98		
300	2	6.50	0.88	3.62	5.00	8	0.75	4.25	3.250	0.312	0.469	0.03	R23	
	2.5	7.50	1.00	4.12	5.88	8	0.88	5.00	4.000	0.312	0.469	0.03	R26	
	3	8.25	1.12	5.00	6.62	8	0.88	5.75	4.875	0.312	0.469	0.03	R31	
	4	10.00	1.25	6.19	7.88	8	0.88	6.88	5.875	0.312	0.469	0.03	R37	
	6	12.50	1.44	8.50	10.62	12	0.88	9.50	8.312	0.312	0.469	0.03	R45	
	8	15.00	1.62	10.62	13.00	12	1.00	11.88	10.625	0.312	0.469	0.03	R49	
	10	17.50	1.88	12.75	15.25	16	1.12	14.00	12.750	0.312	0.469	0.03	R53	
	12	20.50	2.00	15.00	17.75	16	1.25	16.25	15.000	0.312	0.469	0.03	R57	
	14	23.00	2.12	16.25	20.25	20	1.25	18.00	16.500	0.312	0.469	0.03	R61	
	16	25.50	2.25	18.50	22.50	20	1.38	20.00	18.500	0.312	0.469	0.03	R65	
	18	28.00	2.38	21.00	24.75	24	1.38	22.62	21.000	0.312	0.469	0.03	R69	
	20	30.50	2.50	23.00	27.00	24	1.38	25.00	23.000	0.375	0.531	0.06	R73	
	22	33.00	2.62	25.25	29.25	24	1.62	27.00	25.000	0.438	0.594	0.06	R81	
	24	36.00	2.75	27.25	32.00	24	1.62	29.50	27.250	0.438	0.656	0.06	R77	
	26	38.25	3.31	29.50	34.50	28	1.75	31.88	29.500	0.500	0.781	0.06	R93	
	28	40.75	3.56	31.50	37.00	28	1.75	33.88	31.500	0.500	0.781	0.06	R94	
30	43.00	3.75	33.75	39.25	28	1.88	36.12	33.750	0.500	0.781	0.06	R95		
32	45.25	3.94	36.00	41.50	28	2.00	38.75	36.000	0.562	0.906	0.06	R96		
34	47.50	4.12	38.00	43.50	28	2.00	40.75	38.000	0.562	0.906	0.06	R97		
36	50.00	4.38	40.25	46.00	32	2.12	43.00	40.250	0.562	0.906	0.06	R98		

# Flange Dimensions - ANSI B16.5 & B16.47

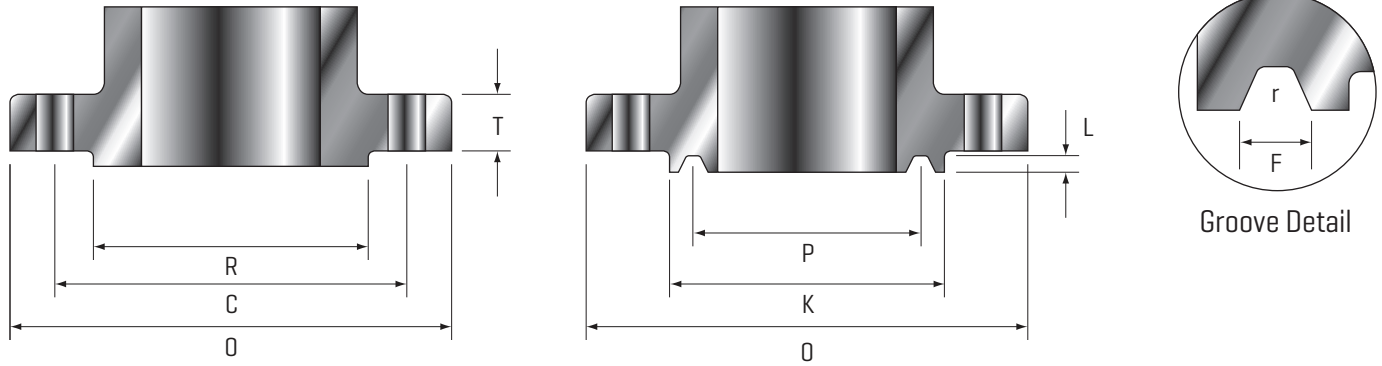

Class	Size	Flg. Dia.	Flg. Thick.	Raised Face Dia.	Drilling			Face Dia.	Ring Joint				
					Bolt Circle Dia.	# of Bolts	Hole Dia.		Pitch Dia.	Grv. Depth	Grv. Width	Btm. Radius	Ring No.
					O	T	R	C	K	P	L	F	r
600	2	6.50	1.00	3.62	5.00	8	0.75	4.25	3.250	0.312	0.469	0.03	R23
	2.5	7.50	1.12	4.12	5.88	8	0.88	5.00	4.000	0.312	0.469	0.03	R26
	3	8.25	1.25	5.00	6.62	8	0.88	5.75	4.875	0.312	0.469	0.03	R31
	4	10.75	1.50	6.19	8.50	8	1.00	6.88	5.875	0.312	0.469	0.03	R37
	6	14.00	1.88	8.50	11.50	12	1.12	9.50	8.312	0.312	0.469	0.03	R45
	8	16.50	2.19	10.62	13.75	12	1.25	11.88	10.625	0.312	0.469	0.03	R49
	10	20.00	2.50	12.75	17.00	16	1.38	14.00	12.750	0.312	0.469	0.03	R53
	12	22.00	2.62	15.00	19.25	20	1.38	16.25	15.000	0.312	0.469	0.03	R57
	14	23.75	2.75	16.25	20.75	20	1.5	18.00	16.500	0.312	0.469	0.03	R61
	16	27.00	3.00	18.50	23.75	20	1.62	20.00	18.500	0.312	0.469	0.03	R65
	18	29.25	3.25	21.00	25.75	20	1.75	22.62	21.000	0.312	0.469	0.03	R69
	20	32.00	3.50	23.00	28.50	24	1.75	25.00	23.000	0.375	0.531	0.06	R73
22	34.25	3.75	25.25	30.62	24	1.88	27.00	25.000	0.438	0.594	0.06	R81	
24	37.00	4.00	27.25	33.00	24	2.00	29.50	27.250	0.438	0.659	0.06	R77	
900	2	8.5	1.5	3.62	6.5	8	1	4.88	3.75	0.312	0.469	0.03	R24
	2.5	9.62	1.62	4.12	7.50	8	1.12	5.39	4.250	0.312	0.469	0.03	R27
	3	9.50	1.50	5.00	7.50	8	1.00	6.12	4.875	0.312	0.469	0.03	R31
	4	11.50	1.75	6.19	9.25	8	1.25	7.12	5.875	0.312	0.469	0.03	R37
	6	15.50	2.19	8.50	12.50	12	1.25	9.50	8.312	0.312	0.469	0.03	R45
	8	18.50	2.50	10.62	15.50	12	1.50	12.12	10.625	0.312	0.469	0.03	R49
	10	21.50	2.75	12.75	18.50	16	1.50	14.25	12.750	0.312	0.469	0.03	R53
	12	24.00	3.12	15.00	21.00	20	1.50	16.50	15.000	0.312	0.469	0.03	R57
	14	25.25	3.38	16.25	22.00	20	1.62	18.38	16.500	0.438	0.656	0.06	R62
	16	27.75	3.50	18.50	24.25	20	1.75	20.62	18.500	0.438	0.656	0.06	R66
	18	31.00	4.00	21.00	27.00	20	2.00	23.38	21.00	0.500	0.781	0.06	R70
	20	33.75	4.25	23.00	29.50	20	2.12	25.50	23.000	0.500	0.781	0.06	R74
24	41.00	5.50	27.25	35.50	20	2.62	30.38	27.250	0.625	1.062	0.09	R78	
1500	2	8.50	1.50	3.62	6.50	8	1.00	4.88	3.750	0.312	0.469	0.03	R24
	2.5	9.62	1.62	4.12	7.50	8	1.12	5.38	4.250	0.312	0.469	0.03	R27
	3	10.50	1.88	5.00	8.00	8	1.25	6.62	5.375	0.312	0.469	0.03	R35
	4	12.25	2.12	6.19	9.50	8	1.38	7.62	6.375	0.312	0.469	0.03	R39
	6	15.50	3.25	8.50	12.50	12	1.50	9.75	8.312	0.375	0.531	0.06	R46
	8	19.00	3.62	10.62	15.50	12	1.75	12.50	10.625	0.438	0.656	0.06	R50
	10	23.00	4.25	12.75	19.00	12	2.00	14.62	12.750	0.438	0.656	0.06	R54
	12	26.00	4.88	15.00	22.50	16	2.12	17.25	15.000	0.562	0.906	0.06	R58
	14	29.50	5.25	16.25	25.00	16	2.38	19.25	16.500	0.625	1.062	0.09	R63
	16	32.50	5.75	18.50	27.75	16	2.62	21.50	18.500	0.688	1.188	0.09	R67
	18	36.00	6.38	21.00	30.50	16	2.88	24.12	21.000	0.688	1.188	0.09	R71
	20	38.75	7.00	23.00	32.75	16	3.12	26.50	23.000	0.688	1.312	0.09	R75
24	46.00	8.00	27.25	39.00	16	3.62	31.25	27.250	0.812	1.438	0.09	R79	
2500	2	9.25	2.00	3.62	6.75	8	1.00	4.48	4.000	0.312	0.469	0.030	R26
	2.5	10.50	2.25	4.12	7.75	8	1.13	5.86	4.375	0.375	0.531	0.060	R28
	3	12.00	2.62	5.00	9.00	8	1.25	6.61	5.000	0.375	0.531	0.060	R32
	4	14.00	3.00	6.19	10.75	8	1.50	7.99	6.188	0.438	0.656	0.060	R38
	5	16.50	3.62	7.31	12.75	8	1.75	9.48	7.500	0.500	0.781	0.060	R40
	6	19.00	4.25	8.50	14.50	8	2.00	10.98	9.000	0.500	0.781	0.060	R47
	8	21.75	5.00	10.62	17.25	12	2.00	13.38	11.000	0.562	0.906	0.060	R51
	10	26.50	6.50	12.75	21.75	12	2.50	16.73	13.500	0.688	1.188	0.090	R55
12	30.00	7.25	15.00	24.38	12	2.75	19.48	16.000	0.688	1.312	0.090	R60	

# Terms & Conditions

## Quotation Validity

This quotation is valid for 30 days from the date quotation is sent. Validity on special metals, including Stainless Steel, is 14 days from the date the quotation is sent. All products offered from stock are subject to prior sale.

## Shipments

All items quoted are EXW our Dock - [Ex Works - SCV Valve Facility Santa Fe, Texas 77510] - unless otherwise noted and agreed to in writing. Shipment may be billed either third party billing to the buyer or freight collect. Shipment dates offered above are forecasted delivery lead times and are estimated from the date payment terms [acceptable to seller] are established, clarification is received on all technical information, and resolution of customer's written approval of drawings is received [when required]. The equipment quoted shall be packed in accordance with seller's standard packing procedure unless otherwise noted and agreed to in writing by the seller.

## Force Majeure

If in the case of an act of God, war, riot, fire, explosion, flood, or any other circumstances of whatsoever nature which are beyond the control of the seller and which in any way affect the ability of the seller to fulfill its delivery obligations, the delivery is hindered, impeded, or delayed the seller shall be exonerated from all responsibilities and reserves the right to postpone the delivery beyond the original schedule.

## Payment terms

All terms are to be negotiated. Credit cards accepted [Master Card, Visa, American Express].

## Purchase Orders

All buyer's purchase orders supplied to the seller are to be written in the English language.

## Prices

All prices quoted are in USD as per the preceding pricing schedule. The minimum order value is \$5,000.00 [five thousand dollars], unless otherwise agreed to by seller. If for some reason any items are changed or additions to the order required, seller reserves the right to adjust prices accordingly. All sales are subject to approval of seller's credit department. If buyer fails to meet the agreed upon and established commercial terms of the contract, the seller may with-hold all subsequent deliveries until such time that the original commercial terms of the contract have been met by the buyer [or subsequent commercial terms have been agreed upon by the seller with the buyer].

## Intellectual Property

All specifications, illustrations, drawings, certificates, and other particulars supplied by seller remain the intellectual property of the seller and should not be disclosed to any third party without the prior written consent of seller.

## Governing Law; Arbitration; Jurisdiction

The terms and conditions of this quotation and any subsequent purchase order shall be construed, interpreted, and performed exclusively according to the laws of the State of Texas, USA. The courts of such state shall have exclusive jurisdiction out of all controversies arising out of or in connection with this agreement. The parties consent that process may be served upon them in any such action by registered mail at the address stated for Buyer on its purchase order, and upon SCV Valve at the address noted above in Santa Fe, Texas, or personally within or without the State of Texas. Any legal action with respect to any agreement must be commenced within one year after the cause of action has accrued. The provisions of the Uniform Commercial Code as adopted by the State of Texas, and not under the United Nations Convention on Contracts for the International Sale of Goods, shall apply.

## Warranty

All seller's products are guaranteed against defects in workmanship for a period of twelve [12] months after being placed in service, but not exceeding eighteen [18] months after shipment, when products are properly installed per seller specifications and used within the service and pressure range for which they were manufactured. Full risk of loss shall pass to the buyer upon delivery at FOB point, or destination port in case of CIF. This guarantee is limited to the replacement of any valve parts/components found to be defective either in material or workmanship. This guarantee does not extend to costs of labor, freight, or any other consequential charges. The unauthorized use of third party components and workmanship in seller's products voids this warranty.

## Limitation of Liability

The liability of the seller under this agreement or with respect to any products supplied or services performed pursuant to this agreement, whether in contract, in tort, in strict liability or otherwise, shall not exceed the purchase price paid by the buyer with respect thereto. In no event will the seller be liable in contract, in tort, in strict liability or otherwise for any special, indirect, incidental, or consequential damages. This is including but not limited to loss of anticipated profits or revenues, loss of use, non-operation or increased expense of operation of equipment, cost of capital, or claims from customer or buyer for failure or delay in achieving anticipated profits or products.

## Cancellation

No contract may be canceled by the buyer except upon written notice to seller and upon payment to seller of all costs incurred by the contract arising out of, or in connection with, the contract. Export of goods covered hereby is subject to United States Customs Control. Standard stocking items will be subject to a twenty-five percent [25%] restocking and/or cancellation charge. Non-standard stocking items will be subject to a one-hundred percent [100%] restocking and/or cancellation charge.

## Cancellation Charge

The following indicates the rates of cancellation charge of contract value for project manufactured items and/or special engineered items at various stages of production:

- |  |                                  |
|--|----------------------------------|
| • <b>Time of cancellation: Order Acknowledgement and prior to Engineering engagement.</b>          | <b>Cancellation Charge: 10%</b>  |
| • <b>Time of cancellation: After start of engineering but prior to release to production.</b>      | <b>Cancellation Charge: 30%</b>  |
| • <b>Time of cancellation: After release to production but prior to completion of fabrication.</b> | <b>Cancellation Charge: 80%</b>  |
| • <b>Time of cancellation: After completion of fabrication.</b>                                    | <b>Cancellation Charge: 100%</b> |

## Return of Goods

No product shall be returned to seller without written authorization and shipping instructions having been obtained from seller. Products authorized for returns are to be shipped freight pre-paid to the SCV Valve Facility identified in writing, unless otherwise notified, and are subject to seller's standard re-stocking fees.

## Documentation

MTR's are available at no charge upon request. The seller's standard document package is per ISO 10474 3.1B requirements. Additional requested documentation is subject to charge.

## Inspection

The customer or his authorized representative may, with four [4] weeks prior notice given to seller, visually inspect products manufactured by seller. Such seller approved inspections will be carried out in accordance with seller's standard or seller approved customer inspection procedures. If any inspection or documentation requested by the customer is over and beyond the scope and criteria initially agreed to by the seller, any costs incurred by conducting such inspection or preparation of special documents shall be paid by the buyer prior to release of the items for shipment.

## Witness Hydro-testing

Witness hydro-testing is available at a cost. A scope of buyers inspection request is to be provided to seller at order placement. Late notice of such requested inspection is subject to additional costs. The cost associated with such witness hydro request is to be agreed on prior to any such testing taking place. Payment of this type of testing to be negotiated. Additionally, any costs associated with a third party inspector will not be at the sellers expense.

The SCV valve brand was established in 1972 as a maintenance and modification company with the ability to provide full in-line valve service and repair. In the mid-1970's, after experiencing many shortcomings of other valve products in the industry, the first SCV valve was manufactured. Since that time, the SCV brand has been expanded its manufactured products to cover a broad range of valves. Industries served include the power, paper and pulp, oil and gas, and petro-chemical sectors.

SCV Valve takes sincere pride in our ability to manufacture both commodity and specialty valves that meet and exceed the needs of our customers. All sizes, pressure classes, and metallurgical compositions are managed in house utilizing the strictest quality control measures to ensure the customer's total satisfaction.

SCV Valve products include thru conduit gates, trunnion mounted balls, floating balls, wedge gates, full port swing checks, piston checks, and lubricated plugs. Valves utilized throughout the industry must meet rigorous quality and production standards.

SCV Valve has earned its API 6A, API 6D, ISO: 9001, CE-PED, and CRN certifications while operating under the API Q1 Quality Management System.

With years of dedication and commitment to quality, design, and service, SCV Valve has grown to be one of the premier valve manufacturers in the industry with the largest inventory of high pressure ball, gate, and check valves. We pride ourselves on our high quality products, timely delivery capabilities, and competitive prices.

On behalf of all of the members at SCV Valve, we thank you for the opportunity to earn your business.

Sincerely,

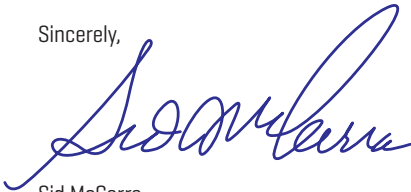

Sid McCarra

President

SCV Valve, LLC

Since 1972, the SCV brand has been committed to providing quality flow control products to the Power, Paper & Pulp, Oil & Gas, and Petro Chemical industries.

As one of the largest valve manufacturers, SCV Valve's reputation is unparalleled for producing high quality commodity and specialty valves. Products range in sizes 1/2" - 48", in pressure classes from 150# - 2500# and are backed by timely deliveries and competitive prices.

**SALES, PROJECTS, ENGINEERING,  
MANUFACTURING, & WAREHOUSING**

3521 FM 646 Rd. North  
Santa Fe, TX 77510

**Fax:** [281] 482-9728



**SCV VALVE**

**[281] 482-4728 • [www.scvvalve.com](http://www.scvvalve.com)**