

Model DA10D - Protocol Converter and Data Acquisition System

- CONFIGURED USING CRIMSON® 3.1 SOFTWARE
- TWO SERIAL COMMUNICATION PORTS, (1 RS-232 and 1 RS-232/422/485)
- 10 BASE T/100 BASE-TX ETHERNET PORT COMMUNICATES WITH UP TO FOUR PROTOCOLS SIMULTANEOUSLY
- UNIT'S CONFIGURATION IS STORED IN NON-VOLATILE FLASH MEMORY
- SD CARD SOCKET FOR LOADING DATABASE IN FIELD
- RUGGED IP40-RATED ENCLOSURE
- THREE FRONT FACE LED INDICATORS
- SUPPORTS OVER 300 INDUSTRIAL PROTOCOLS
- POWER UNIT FROM 24 ±20% VDC



GENERAL DESCRIPTION

The DA10D data station performs the functions of a multiple protocol converter, using two high-speed serial communications ports and a 10/100 Base-TX Ethernet port. The Ethernet port supports up to four protocols simultaneously, allowing dissimilar Ethernet based products to communicate with one another, including PLCs, motor drives, bar code scanners, etc. The SD card slot can be used to load the unit's configuration file, allowing configuration changes to be made and saved to the card for later transfer.

The DA10D is programmed with Red Lion's Crimson 3.1 software. Crimson offers easy to use drag and drop communications configuration and is available as a no charge download from Red Lion's website.

DIMENSIONS In inches (mm)

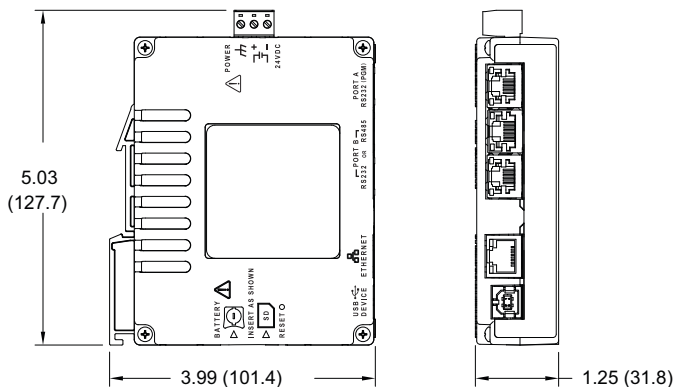

SAFETY SUMMARY

All safety related regulations, local codes and instructions that appear in the manual or on equipment must be observed to ensure personal safety and to prevent damage to either the instrument or equipment connected to it. If equipment is used in a manner not specified by the manufacturer, the protection provided by the equipment may be impaired.

Do not use the unit to directly command motors, valves, or other actuators not equipped with safeguards. To do so can be potentially harmful to persons or equipment in the event of a fault to the unit.



CAUTION: Risk of Danger.

Read complete instructions prior to installation and operation of the unit.

CONTENTS OF PACKAGE

- DA10D
- Terminal block for connecting power

ORDERING INFORMATION

MODEL NO.	DESCRIPTION	PART NUMBER
DA10D	Protocol Converter with 2 Serial Ports, 1 Ethernet Port, and USB Device Port	DA10D 0C 000000 000
SD	SD Card ¹	SDxxxxxx
CBL	Communications Cables and Adapter ¹	CBLxxxxx
CRA000	Replacement Battery	CRA000 BT3V0 00000

¹ Contact your Red Lion distributor or visit our website for selection of SD cards, adapters and cables.

SPECIFICATIONS

1. POWER REQUIREMENTS:

Must use a Class 2 circuit according to National Electrical Code (NEC), NFPA-70 or Canadian Electrical Code (CEC), Part I, C22.1 or a Limited Power Supply (LPS) according to IEC 60950-1 or Limited-energy circuit according to IEC 61010-1.

Power connection via removable three position terminal block.

Supply Voltage: 24 VDC \pm 20%, Class 2 source

Typical Power: 1.9 W

Max Power: 3.5 W

2. BATTERY: Lithium coin cell. Typical lifetime of 5 years, nominal.

To maintain UL rating, replacement battery must be: Red Lion CRA000 BT3V0 00000, Rayovac BR1225X-BA or Panasonic BR1225A/BN.

3. MEMORY:

On Board User Memory: 512 Mbyte of non-volatile Flash memory.

Memory Card: SD slot accepts standard capacity cards up to 16 GB.

4. COMMUNICATION CAPABILITIES:

USB Device Port: Isolated and adheres to USB specification 2.0 full speed only using Type B connection. **USB DEVICE PORT IS FOR SYSTEM SET-UP AND DIAGNOSTICS AND IS NOT INTENDED FOR PERMANENT CONNECTION.**

Serial Ports (2): Ports are individually isolated. Format and Baud Rates for each port are individually software programmable up to 115,200 baud.

Port to Port Isolation: 1500 Vrms for 1 minute.

Signal Isolation: 500 V.

Ethernet Port: 10 BASE-T / 100 BASE-TX

RJ45 jack is wired as a NIC (Network Interface Card).

Isolation from Ethernet network to operator interface: 1500 Vrms

5. ENVIRONMENTAL CONDITIONS:

Operating Temperature Range: -10 to 50 °C

Storage Temperature Range: -20 to 70 °C

Vibration to IEC 68-2-6: Operational 5-500 Hz, 2 g

Shock to IEC 68-2-27: Operational 30 g

Operating and Storage Humidity: 0 to 85% max. RH non-condensing

Altitude: Up to 2000 meters

Installation Category II, Pollution Degree 2 as defined in IEC/EN 60664-1.

6. CERTIFICATIONS AND COMPLIANCES:

CE Approved

Immunity: IEC/EN 61000-6-2 for Industrial Locations

Emissions: IEC/EN 61000-6-4 for Industrial Locations; CISPR 11 Class A

IEC/EN 61010-1

RoHS Compliant

UL Listed: File #E302106

Rugged IP40 enclosure

7. CONNECTIONS: High compression cage-clamp terminal block

Wire Strip Length: 0.3" (7.5 mm)

Wire Gauge Capacity: 12 to 24 AWG (3.31 to 0.20 mm²) copper wire

Torque: 4.4-5.3 inch-lbs (0.5-0.6 N-m)

8. CONSTRUCTION: Polycarbonate enclosure with IP40 rating. For indoor use only.

9. MOUNTING REQUIREMENTS: Snaps onto standard DIN style top hat (T) profile mounting rails according to EN50022 – 35 x 7.5 mm and 35 x 15 mm.

10. WEIGHT: 6.8 oz (192.78 g)

INSTALLING AND POWERING THE DA10D

MOUNTING INSTRUCTIONS

DIN rail should be mounted horizontally so that the unit's ventilation holes are vertical in relation to cabinet orientation. A minimum clearance of 1 inch (25.4 mm) should be maintained above and below the unit in order to ensure proper thermal regulation.

Figure 1 - Attach DAx0D To DIN Rail

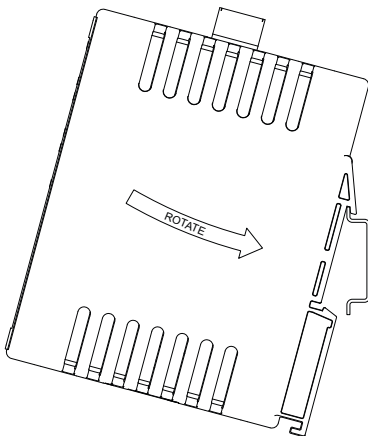

The unit shall be installed inside a UL Listed Industrial Control Panel or similar type of enclosure. A minimum 3.2 mm distance shall be maintained between the hazardous live parts of the equipment and accessible parts of the fire/electrical enclosure.

This device is open-type and must be mounted in a suitable dust-tight end-enclosure in accordance with articles 500 and 502 of the National Electric Code (NEC).

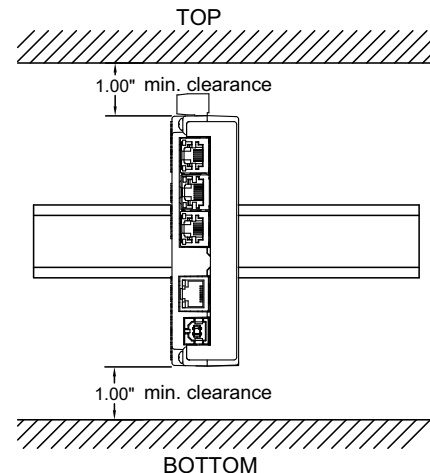

CONNECTING POWER

The DA10D requires a 24 VDC $\pm 20\%$ power supply. A pluggable power block is provided to connect the 24 VDC. There are three screw terminals. Strip and connect the wire according to the terminal block specifications on Page 2. Connect the positive lead to the plus (+) screw and the negative lead to the minus (-) screw.

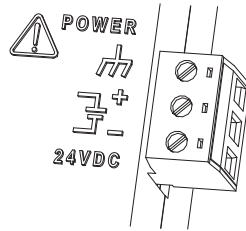

Please take care to observe the following points:

- Mount the power supply close to the unit, with usually not more than 6 feet (1.8 m) of cable between the supply and the operator interface. Ideally, the shortest length possible should be used.
- The wire used to connect the operator interface's power supply should be at least 22-gage wire suitably rated for the temperatures of the environment to which it is being installed. If a longer cable run is used, a heavier gage wire should be used. The routing of the cable should be kept away from large contactors, inverters, and other devices which may generate significant electrical noise.
- A power supply with an NEC Class 2 or Limited Power Source (LPS) and SELV rating is to be used. This type of power supply provides isolation to accessible circuits from hazardous voltage levels generated by a mains power supply due to single faults. SELV is an acronym for "safety extra-low voltage." Safety extra-low voltage circuits shall exhibit voltages safe to touch both under normal operating conditions and after a single fault, such as a breakdown of a layer of basic insulation or after the failure of a single component has occurred. A suitable disconnect device shall be provided by the end user.

CONNECTING TO EARTH GROUND

The third pin of the power connector is chassis ground for the unit. Your unit should be connected to earth ground. Steps should be taken beyond connecting to earth ground to eliminate the buildup of electrostatic charges.

The chassis ground is not connected to signal common of the unit. Maintaining isolation between earth ground and signal common is not required to operate your unit. But, other equipment connected to this unit may require isolation between signal common and earth ground. *To maintain isolation between signal common and earth ground care must be taken when connections are made to the unit.* For example, a power supply with isolation between its signal common and earth ground must be used. Also, plugging in a USB cable may connect signal common and earth ground.¹

¹ USB's shield may be connected to earth ground at the host. USB's shield in turn may also be connected to signal common.

EMC INSTALLATION GUIDELINES

Although Red Lion Controls products are designed with a high degree of immunity to Electromagnetic Interference (EMI), proper installation and wiring methods must be followed to ensure compatibility in each application. The type of the electrical noise, source or coupling method into a unit may be different for various installations. Cable length, routing, and shield termination are very important and can mean the difference between a successful or troublesome installation. Listed are some EMI guidelines for a successful installation in an industrial environment.

1. A unit should be mounted in a metal enclosure, which is properly connected to protective earth.
2. Use shielded cables for all Signal and Control inputs. The shield connection should be made as short as possible. The connection point for the shield depends somewhat upon the application. Listed below are the recommended methods of connecting the shield, in order of their effectiveness.
 - a. Connect the shield to earth ground (protective earth) at one end where the unit is mounted.
 - b. Connect the shield to earth ground at both ends of the cable, usually when the noise source frequency is over 1 MHz.

3. Never run Signal or Control cables in the same conduit or raceway with AC power lines, conductors, feeding motors, solenoids, SCR controls, and heaters, etc. The cables should be run through metal conduit that is properly grounded. This is especially useful in applications where cable runs are long and portable two-way radios are used in close proximity or if the installation is near a commercial radio transmitter. Also, Signal or Control cables within an enclosure should be routed as far away as possible from contactors, control relays, transformers, and other noisy components.
4. Long cable runs are more susceptible to EMI pickup than short cable runs.
5. In extremely high EMI environments, the use of external EMI suppression devices such as Ferrite Suppression Cores for signal and control cables is effective. The following EMI suppression devices (or equivalent) are recommended:
 - Fair-Rite part number 0443167251 (Red Lion Controls #FCOR0000)
 - Line Filters for input power cables:
 - Schaffner # FN2010-1/07 (Red Lion Controls #LFIL0000)
6. To protect relay contacts that control inductive loads and to minimize radiated and conducted noise (EMI), some type of contact protection network is normally installed across the load, the contacts or both. The most effective location is across the load.
 - a. Using a snubber, which is a resistor-capacitor (RC) network or metal oxide varistor (MOV) across an AC inductive load is very effective at reducing EMI and increasing relay contact life.
 - b. If a DC inductive load (such as a DC relay coil) is controlled by a transistor switch, care must be taken not to exceed the breakdown voltage of the transistor when the load is switched. One of the most effective ways is to place a diode across the inductive load. Most Red Lion products with solid state outputs have internal zener diode protection. However external diode protection at the load is always a good design practice to limit EMI. Although the use of a snubber or varistor could be used.
 - Red Lion part numbers: Snubber: SNUB0000
 - Varistor: ILS11500 or ILS23000
7. Care should be taken when connecting input and output devices to the instrument. When a separate input and output common is provided, they should not be mixed. Therefore a sensor common should NOT be connected to an output common. This would cause EMI on the sensitive input common, which could affect the instrument's operation.

COMMUNICATING WITH THE DA10D

CONFIGURING A DA10D

The DA10D is configured using Crimson® 3.1 software. Crimson is available as a no charge download from Red Lion's website. Crimson updates for new features and drivers are posted on the website as they become available. By configuring the DA10D using the latest Crimson version, you are assured that your unit has the most up to date feature set. Crimson software can configure the DA10D through the RS232 PGM port, USB port, or SD card.

The DA10D has two serial ports, a USB device port, and an Ethernet port as shown below.

The two serial ports are available via RJ connectors. The port labeled RS232 (PGM) can be used as a Programming Port or you can assign a protocol to it. The other logical port is a combination port that provides either a RS232 or RS485/422 connection. Only one connection (RS232 or RS485/422) can be used at a time. The RS485 port can be used for both RS485 or 422 communications.

The Ethernet port can be programmed to communicate via four protocols simultaneously. For more information on protocol support, please refer to the Crimson 3.1 User Manual.

The USB device port is a standard device port with a Type B connector, and is used as the programming port. The driver needed to use the USB port will be installed with Crimson.

The SD card can be used to program a DA10D by placing a database image file on the SD card. The card is then inserted into the target DA10D and powered. Refer to the Crimson 3.1 User Manual for more information on the naming convention and location for this file.

INSERTION/REMOVAL OF THE SD CARD

Insert the SD card into the slot provided with the card oriented as shown. The card is inserted properly when the end of the card is flush with the DAX0D case. To remove the SD card, push in slightly on the card.

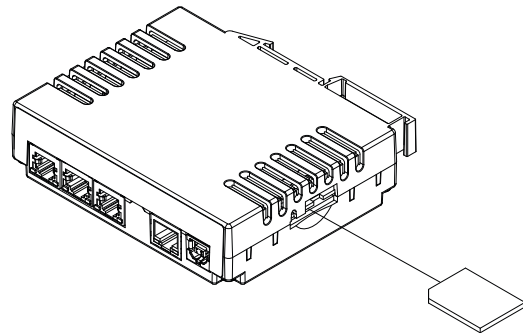

CABLES AND DRIVERS

Red Lion has a wide range of cables and drivers for use with many different communication types. A list of these drivers and cables along with pin outs is available from Red Lion's website. New cables and drivers are added on a regular basis. If making your own cable, refer to the "Port Pin Outs" that corresponds to your specific model for wiring information.

ETHERNET COMMUNICATIONS

Ethernet communications can be established at either 10 BASE-T or 100 BASE-TX. The unit's RJ45 jack is wired as a NIC (Network Interface Card). It auto-detects remote transmit and receive pairs and correctly assigns the transmit and receive pairs. This feature enables the user to use whichever type of cable (cross-over or straight) is available.

The Ethernet connector contains two LEDs. A yellow LED in the upper right, and a green LED in the upper left. The LEDs represent the following statuses:

LED COLOR	DESCRIPTION
YELLOW solid	Link established.
YELLOW flashing	Data being transferred.
GREEN (OFF)	10 BASE-T Communications
GREEN (ON)	100 BASE-TX Communications

On the rear of each unit is a unique 12-digit MAC address. Refer to the Crimson manual and Red Lion's website for additional information on Ethernet communications.

DA10D PORT PIN OUTS

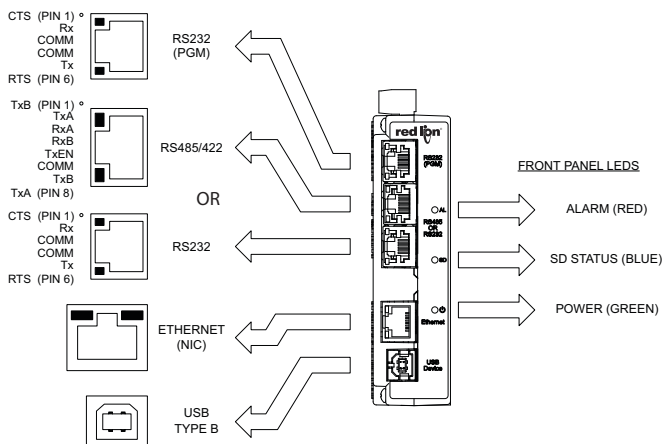

USB, DATA TRANSFERS FROM THE SD CARD

In order to transfer data from the SD card via the USB port, a driver must be installed on your computer. This driver is installed with Crimson and is located in the folder C:\Program Files\Red Lion Controls\Crimson 3.1\Device\ after Crimson is installed. This may have already been accomplished if your DAX0D was configured using the USB port.

Once the driver is installed, connect the DAX0D to your PC with a USB cable, and refer to the "Mounting the SD Card" section in the Crimson 3.1 User Manual.

RS232 PORTS

The DA10D has two serial ports. There is the RS232 PGM port and the RS232/RS422/485 COMMS port. Although only one of these ports can be used for programming, both ports can be used for communications with a PLC. The serial ports can be used for either master or slave protocols with any DAX0D configuration. Each serial port has a pair of LEDs to indicate transmit and receive activity. The pinouts are shown here.

DAX0D RS232 TO A PC			
DAX0D: RJ12	Name	PC: DB9	Name
4	COMM	1	DCD
5	Tx	2	Rx
2	Rx	3	Tx
	N/C	4	DTR
3	COMM	5	GND
	N/C	6	DSR
1	CTS	7	RTS
6	RTS	8	CTS
	N/C	9	RI

RS232/RS422/485 COMMS PORT

The one logical serial port of the DA10D can be used as a RS232 or RS422/485 port. There is a separate RJ connector for each option. In addition, the RS485/422 option can be configured to act as either RS485 or RS422. Each serial port has a pair of LEDs to indicate transmit and receive activity.

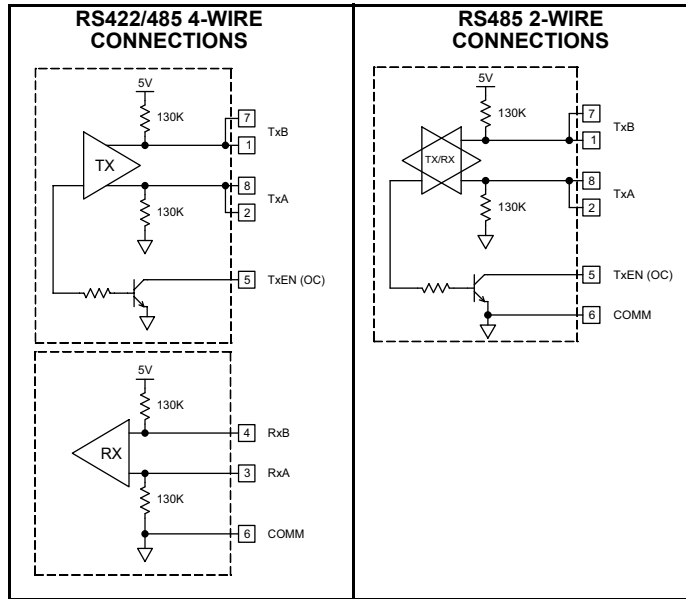

Note: All Red Lion devices connect A to A and B to B. Refer to www.redlion.net for additional information.

Examples of RS485 2-Wire Connections

DAX0D TO RED LION RJ11			
DAx0D:RJ45	Name	RLC:RJ11	Name
5	TxEN	2	TxEN
6	COMM	3	COMM
1	TxB	5	B-
2	TxA	4	A+

DAX0D TO RED LION RJ45			
DAx0D	Name	RLC:RJ45	Name
1,4	TxB	1,4	TxB
4,1	RxB	4,1	RxB
2,3	TxA	2,3	TxA
3,2	RxA	3,2	RxA
5	TxEN	5	TxEN
6	COMM	6	COMM
7	TxB	7	TxB
8	TxA	8	TxA

DH485 COMMUNICATIONS

The DA10D's RS422/485 COMMS port can also be used for Allen Bradley DH485 communications.

WARNING: DO NOT use a standard DH485 cable to connect this port to Allen Bradley equipment.

SOFTWARE/UNIT OPERATION

CRIMSON® 3.1 SOFTWARE

Crimson 3.1 software is available as a no charge download from Red Lion's website. The latest version of the software is always available from the website, and updating your copy is free.

STATUS LEDS

There are three status LEDs that show system status by default, or they may be user configured via System Functions using Crimson 3.1. Shown below is the default system status of the LEDs.

LED	INDICATION
GREEN	
STEADY	Unit is powered.
BLUE	
FLASHING	Unit is in the boot loader
OFF	No SD card is present.
STEADY	Valid SD card present.
FLASHING RAPIDLY	SD card being checked.
FLICKERING	SD card accessed.
FLASHING SLOWLY	Incorrectly formatted SD card present.
RED	
FLASHING	Data tag is in an alarm active state.
STEADY	Data tag is in an alarm accepted state.

FACTORY RESET BUTTON

The factory reset button located on the bottom of the unit enclosure near the SD card slot can be used to access the system console.

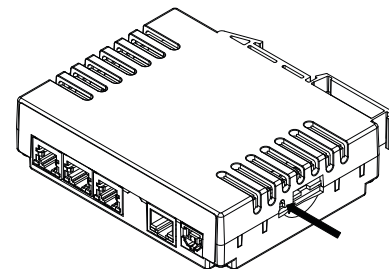

TROUBLESHOOTING YOUR DAX0D

If for any reason you have trouble operating, connecting, or simply have questions concerning your new DAX0D unit, contact Red Lion's technical support.

BATTERY & TIME KEEPING

A battery is used to keep time when the unit is without power. The battery of a DAx0D unit does not affect the unit's memory, all configurations and data is stored in non-volatile memory.

Changing the Battery

To change the battery of a DAx0D, first remove power to the unit. Remove the SD card if one is installed. Insert a small screwdriver into the slot provided on the battery holder and pry the battery holder with battery out of the unit. Remove the old battery from the plastic holder and replace it with a new battery. Make sure the orientation of the battery is correct and as shown in the diagram.

Re-install the battery holder with battery into the DAx0D unit. Enter new date and time using Crimson 3.1 software.

To maintain UL rating, battery must be replaced with one listed in the Specifications.

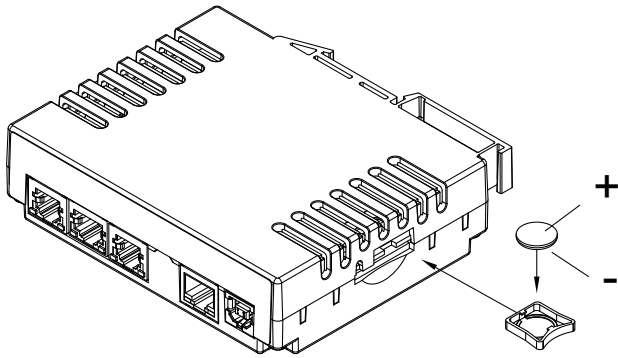

CAUTION: Lithium battery. Danger of explosion if battery is incorrectly replaced. Replace only with the same or equivalent type recommended by the manufacturer.



Please note that the old battery must be disposed of in a manner that complies with your local waste regulations. The battery must not be disposed of in fire, or in a manner whereby it may be damaged and its contents could come into contact with human skin.

TRADEMARK ACKNOWLEDGMENTS

Ethernet is a registered trademark of Xerox Corporation.

All other company and product names are trademarks of their respective owners.

LIMITED WARRANTY

(a) Red Lion Controls Inc., (the "Company") warrants that all Products shall be free from defects in material and workmanship under normal use for the period of time provided in "Statement of Warranty Periods" (available at www.redlion.net) current at the time of shipment of the Products (the "Warranty Period"). **EXCEPT FOR THE ABOVE- STATED WARRANTY, COMPANY MAKES NO WARRANTY WHATSOEVER WITH RESPECT TO THE PRODUCTS, INCLUDING ANY (A) WARRANTY OF MERCHANTABILITY; (B) WARRANTY OF FITNESS FOR A PARTICULAR PURPOSE; OR (C) WARRANTY AGAINST INFRINGEMENT OF INTELLECTUAL PROPERTY RIGHTS OF A THIRD PARTY; WHETHER EXPRESS OR IMPLIED BY LAW, COURSE OF DEALING, COURSE OF PERFORMANCE, USAGE OF TRADE OR OTHERWISE.** Customer shall be responsible for determining that a Product is suitable for Customer's use and that such use complies with any applicable local, state or federal law.

(b) The Company shall not be liable for a breach of the warranty set forth in paragraph (a) if (i) the defect is a result of Customer's failure to store, install, commission or maintain the Product according to specifications; (ii) Customer alters or repairs such Product without the prior written consent of Company.

(c) Subject to paragraph (b), with respect to any such Product during the Warranty Period, Company shall, in its sole discretion, either (i) repair or replace the Product; or (ii) credit or refund the price of Product provided that, if Company so requests, Customer shall, at Company's expense, return such Product to Company.

(d) THE REMEDIES SET FORTH IN PARAGRAPH (c) SHALL BE THE CUSTOMER'S SOLE AND EXCLUSIVE REMEDY AND COMPANY'S ENTIRE LIABILITY FOR ANY BREACH OF THE LIMITED WARRANTY SET FORTH IN PARAGRAPH (a).